



Loop-IP6700 TDMoEthernet



Feature

- 1U height
- WAN port
 - One electric Ethernet (10/100 BaseT) or optical Ethernet (10/100 Base-FX)
- Tributary ports
 - TDM interfaces
 - low speed, up to 4 E1/T1
 - low speed, up to 2 DTE
 - high speed, 1 E3/DS3
 - LAN interface: two 10/100 BaseT Ethernet/SNMP
- Power
 - Single AC or DC power
 - AC (100 to 240 Vac)
 - DC (-20 to -72 Vdc)
- Inband management: through one time slot (64K bps)
- Bridging & Switching
 - VLAN
 - Max. 255 VLAN
 - Q-in-Q
 - Packet transparency (up to 1916 bytes)
- QoS
 - User configurable CoS
 - User configurable ToS in outgoing IP frame
 - Max. 340ms Packet Delay Variation
 - Jitter buffer size: 3 ms to 512 ms
 - Min. packetization (pseudowire) latency < 2 ms
- Supports SNTP
- Built-in BERT for E1/T1
- Jitter & Wander
 - PPM: per G.823 Traffic
 - PPB: per G.823 Synchronous
- Multi-color LED indicators
- Alarm relay
- Management port and interface
 - LCD and keypad
 - Console port with VT100 menu
 - SNMP port:
 - Embedded SNMP
 - Telnet
 - LoopView GUI

Description

Loop-IP6700 TDMoEthernet is used to transport TDM traffic over IP network, in addition to Ethernet traffic. As the core communications network migrates from TDM to IP, the Loop-IP6700 provides a flexible and cost effective choice for the transport of legacy TDM signals.

On the WAN side, the Ethernet interface can be 10/100M electric or optical Ethernet. On the tributary side, the TDM ports can be multiple E1, T1, and DTE, or single E3/DS3, each with timing preserved. The Ethernet port can be 10/100 BaseT.

The Loop-IP6700 has built-in AC or DC power. Management choices include console port, Ethernet port, and SNMP port, in addition to Inband management for communication with remote management centers.

For transport of TDM signals E1, T1, E3, DS3, Jitter and Wander adheres to G.823 Traffic and G.823 Synchronous.

Ordering Information

To specify options, choose from list below:

Note: RoHS compliant units are identified by the letter **G** appearing immediately at the end of ordering code.

Model (non RoHS compliant)	Model (RoHS compliant)	Description	Note
Loop-IP6700-S-EH-PPM-pp-add	Loop-IP6700-S-EH-PPM-pp-add- G	IP6700 with G.823 traffic, an electric Ethernet WAN port, a SNMP port, one E3/DS3 high speed interface and one LAN interface	
Loop-IP6700-S-EL-PPM-aa-bb-cc-dd-pp-add	Loop-IP6700-S-EL-PPM-aa-bb-cc-dd-pp-add- G	IP6700 with G.823 traffic, an electric Ethernet WAN port, a SNMP port, low speed interfaces described below and one LAN interface	
Loop-IP6700-S-OH-PPM-pp-add	Loop-IP6700-S-OH-PPM-pp-add- G	IP6700 with G.823 traffic, an optical Ethernet WAN port, a SNMP port, one E3/DS3 high speed interface and one LAN interface. SFP optical module is not included.	
Loop-IP6700-S-OL-PPM-aa-bb-cc-dd-pp-add	Loop-IP6700-S-OL-PPM-aa-bb-cc-dd-pp-add- G	IP6700 with G.823 traffic, an optical Ethernet WAN port, a SNMP port, low speed interfaces described below and one LAN interface. SFP optical module is not included.	
Loop-IP6700-S-EH-PPB-pp-add	Loop-IP6700-S-EH-PPB-pp-add- G	IP6700 with G.823 synchronous, an electric Ethernet WAN port, a SNMP port, one E3/DS3 high speed interface and one LAN interface	
Loop-IP6700-S-EL-PPB-aa-bb-cc-dd-pp-add	Loop-IP6700-S-EL-PPB-aa-bb-cc-dd-pp-add- G	IP6700 with G.823 synchronous, an electric Ethernet WAN port, a SNMP port, low speed interfaces described below and one LAN interface	
Loop-IP6700-S-OH-PPB-pp-add	Loop-IP6700-S-OH-PPB-pp-add- G	IP6700 with G.823 synchronous, an optical Ethernet WAN port, a SNMP port, one E3/DS3 high speed interface and one LAN interface. SFP optical module is not included.	
Loop-IP6700-S-OL-PPB-aa-bb-cc-dd-pp-add	Loop-IP6700-S-OL-PPB-aa-bb-cc-dd-pp-add- G	IP6700 with G.823 synchronous, an optical Ethernet WAN port, a SNMP port, low speed interfaces described below and one LAN interface. SFP optical module is not included.	
Accessories			
User's Manual			
Loop-IP6700-UM	Loop-IP6700-UM	User's Manual (paper hard copy-optional). A CD version of the manual is already included as standard equipment.	
Power Cord (All power cords are RoHS compliant)			
Loop-ACC-PC-USA	Loop-ACC-PC-USA	AC power cord for Taiwan/America	
Loop-ACC-PC-EU	Loop-ACC-PC-EU	AC power cord for Europe	
Loop-ACC-PC-UK	Loop-ACC-PC-UK	AC power cord for UK	
Loop-ACC-PC-AUS	Loop-ACC-PC-AUS	AC power cord for Australia	
Loop-ACC-PC-CH	Loop-ACC-PC-CH	AC power cord for China	
SFP Optical Module (All SFP Optical Modules are RoHS compliant)			
MHBTW	MHBTW	Multimode optical module with dual uni-directional fiber, 155M, 1310 nm, LC optical connector, 2km reach (11dBm)	- Use 2 fibers for all SFP Optical Modules
PHB3W	PHB3W	single optical module with dual uni-directional fiber, 155M, 1310 nm, LC optical connector, 30 km reach (19dBm)	
PHB5W	PHB5W	single optical module with dual uni-directional fiber, 155M, 1310 nm, LC optical connector, 50 km reach (30dBm)	
PHCUW	PHCUW	single optical module with dual uni-directional fiber, 155M, 1550 nm, LC optical connector, 100 km reach (30dBm)	
PHCXW	PHCXW	single optical module with dual uni-directional fiber, 155M, 1550 nm, LC optical connector, 120 km reach (35dBm)	
PHB3D	PHB3D	single optical module with dual uni-directional fiber, 155M, 1310 nm, LC optical connector with Digital Diagnostic Monitoring, 30 km reach (19dBm)	

PHB5D	PHB5D	single optical module with dual uni-directional fiber, 155M, 1310 nm, LC optical connector with Digital Diagnostic Monitoring, 50 km reach (30dBm)	
PHC8D	PHC8D	single optical module with dual uni-directional fiber, 155M, 1550 nm, LC optical connector with Digital Diagnostic Monitoring, 80 km reach (0dBm)	
PHCUD	PHCUD	single optical module with dual uni-directional fiber, 155M, 1550 nm, LC optical connector with Digital Diagnostic Monitoring, 100 km reach (30dBm)	
PHCXD	PHCXD	single optical module with dual uni-directional fiber, 155M, 1550 nm, LC optical connector with Digital Diagnostic Monitoring, 120 km reach (35dBm)	

NOTE:

1. For other special optical modules, please contact your nearest Loop sales representative.
2. * High Speed for E3/DS3 only (E3/DS3 software programmable)
* Low Speed for T1, E1 and DTE
3. PPM = G.823 Traffic, PPB = G.823 Synchronous

Where aa, bb =

select from list below or leave this area blank
E75 for 75 ohm BNC E1 interface port
E120 for 120 ohm Twisted Pair RJ48C E1 interface port
T1 for T1 interface port

Where cc and dd are optional =

select from list below or leave this area blank
E75 for 75 ohm BNC E1 interface port
E120 for 120 ohm Twisted Pair RJ48C E1 interface port
T1 for T1 interface port
22 for V.35 DTE interface with DB25 connector
33 for EIA530 DTE interface with DB25 connector
44 for X.21 DTE interface via DB25P to DB15S (1-foot) conversion cable
66 for V.36 / RS449 DTE interface via DB25P to DB37S (1-foot) conversion cable
77 for RS422 / V.11 DTE interface with DB25 connector

pp =

DC for -20 to -72 Vdc power source
AC for 100 to 240 Vac power sources (For AC choose an appropriate power cord)

add=

Front panel with LCD and keypad

Examples:

Loop-IP6700-S-EH-PPM-AC-LCD)

A high speed unit with G.823 traffic, electric Ethernet WAN port, one E3/DS3, 100 to 240 Vac power and LCD.

Loop-IP6700-S-EL-PPM-E75-E75-22-22-AC-LCD

A low speed unit with G.823 traffic, electric Ethernet WAN port, two E75 ports, two V.35 DTE ports, 100 to 240 Vac power and LCD

Loop-IP6700-S-OH-PPB-AC

A high speed unit with G.823 synchronous, an optical Ethernet WAN port, one E3/DS3 and 100 to 240 Vac power.

Loop-IP6700-S-OL-PPB-E120-E120-22-22-AC

A low speed unit with G.823 synchronous, an optical Ethernet WAN port, two E120 ports, two V.35 DTE ports and 100 to 240 Vac power.

Loop-IP6700 TDMoEthernet Product Specifications

SFP Optical Module Specification

SFP Optical Module	Fiber Direction	Wavelength (nm)	Connector	Distance (km)	Power (dBm)
MHBTW	Dual uni-directional	1310	LC without DDM	2	11
PHB3W	Dual uni-directional	1310	LC without DDM	30	19
PHB5W	Dual uni-directional	1310	LC without DDM	50	30
PHCUW	Dual uni-directional	1550	LC without DDM	100	30
PHCXW	Dual uni-directional	1550	LC without DDM	120	35
PHB3D	Dual uni-directional	1310	LC with DDM	30	19
PHB5D	Dual uni-directional	1310	LC with DDM	50	30
PHC8D	Dual uni-directional	1550	LC with DDM	80	0
PHCUD	Dual uni-directional	1550	LC with DDM	100	30
PHCXD	Dual uni-directional	1550	LC with DDM	120	35

NOTE: For other special optical modules, please contact your nearest Loop sales representative.

Electric Ethernet WAN Interface

Interface	10/100 BaseT
Connector	RJ45

Optical Ethernet WAN Interface

Speed	100 Base-FX
Connector	SFP 3.3V

E1 Tributary Interface

Line Rate	2.048M bps ± 50 ppm	Input Signal	ITU G.703
Framing	ITU G.704 (CRC: on/off, CAS: on/off, unframed)	Output Signal	ITU G.703
Line Code	AMI/HDB3	Jitter	ITU G.823
Connector	BNC and RJ48C	Electrical	75 ohm coax/120 ohm twisted pair

T1 Tributary Interface

Line Rate	1.544M bps ± 32 ppm	Input Signal	DS-1 from 0 dB to -26 dB w/ALBO
Framing	D4/ ESF/ ESF&T1.403/ NONE (clear channel)	Output Signal	DSX-1, DS-1
Line Code	AMI / B8ZS	Surge Protection	FCC Part 68 Sub-Part D
Connector	RJ48C	Pulse Template	Per AT&T TR 62411

NOTE: E1/T1 (jumper selectable)

DTE (V.35/EIA530/X.21/V.36/RS449/RS422/V.11) Tributary Interface

Data Rate	n x 56K bps (n= 1 to 31) or n x 64K bps (n= 1 to 32)
Connector	DB25S for V.35 DB25S for EIA530 DB15S for X.21 via DB25P to DB15S conversion cable DB37S for V.36/RS449 via DB25P to DB37S conversion cable DB25S for RS422/V.11

E3 Tributary Interface

Data Rate	34.368M bps ± 4.6 ppm	Framing	Unframed
Line Code	HDB3	Output Mask	ETS 300 689 Sec.4.2.1.2 ITU G.703
Connector	BNC connector	Total Ports	1
Impedance	75 ohm coax	Jitter	ITU G.824

DS3 Tributary Interface

Data Rate	44.736M bps ± 4.6 ppm	Framing	Unframed
Line Code	B3ZS	Output Mask	Bellcore GR-499-core
Connector	BNC connector	Total Ports	1
Impedance	75 ohm coax	Jitter	ITU G.824

NOTE: E3/DS3 (software selectable)

Ethernet Switch

VLAN packet transparency (up to 1916 bytes)
Max. 255 VLAN
Supports Q-in-Q
User configurable CoS
User configurable ToS in outgoing IP frame

LAN Tributary Interface

Number of Ports 2
Speed 10/100 BaseT
Connector RJ45

Packet Delay Variation

For E1:	up to 256 ms	For Framed T1:	up to 256 ms
For Unframed T1:	up to 340 ms	For Framed T1 with CAS:	up to 192 ms
For E3:	up to 60 ms	For DS3:	up to 45 ms

SNTP

SNTP client support
Sync with up to 2 time servers

Clock Source

Primary Clock Internal, tributary port (A, B, C or D), WAN port, external (for low speed tributary port E1/T1/DTE only, manufacture option)
Secondary Clock Internal, tributary port (A, B, C or D), WAN port, external (for low speed tributary port E1/T1/DTE only, manufacture option)

External Clock

Input Signal E1 (2.048M bps), 2M bps, 120 ohm
Connector BNC

Alarm Relay

Alarm Relay Fuse alarm, performance alarm
Connector 3 pin terminal block

Network Management

Console Port

Electrical RS232 interface
Protocol Menu driven VT-100 terminal
Connector DB9, female, DCE

SNMP Port

Protocol Telnet (VT100) and Embedded SNMP
Connector RJ45 at front panel

Inband Management

Through any one time slot (64K bps) for low speed ports (E1/T1) with frame mode only
HDLC management protocol

Performance monitors (T1, E1)

Performance Store The last 24 hours performance in 15-minute intervals
Monitor Registers Line, user and remote site
Performance Reports Date & Time, Error second, Unavailable second, Bursty error second, severe error second, controlled slip second, and loss of frame count
Alarm History Date & time, alarm type(i.e. master clock loss, RAI, AIS, LOS, BPV, ES, CSS)
Threshold Second

Diagnostics test (T1, E1)

Loopback Line loopback, payload loopback and local loopback
Remote Loopback Payload loopback

Front Panel

LCD and Keypad
LEDs

Power

Single AC power or DC power.
AC: 100 to 240 Vac, 50/60 Hz
DC: -20 to -72 Vdc
Power Consumption: 10W Max

Physical and Environmental

Dimensions 212.6 x 44 x 197 mm. (W x H x D)
Temperature 0 -50°C
Humidity 0-95% RH (NON-CONDENSING)
Mounting Desk-top stackable, wall mount

Certification

EMC EN55022 Class A, EN50024, EN300 386, FCC Part 15 Subpart B Class A
Safety IEC60950-1(CB), EN60950-1(CE)

Standard Compliance

ITU G.703, G.704, G.706, G.823, G.824, G.826, V.11, PWE3
IETF TDMoIP, SAToP, CESoPSN, 802.1p/Q

Application Illustration

Low Speed TDM Application

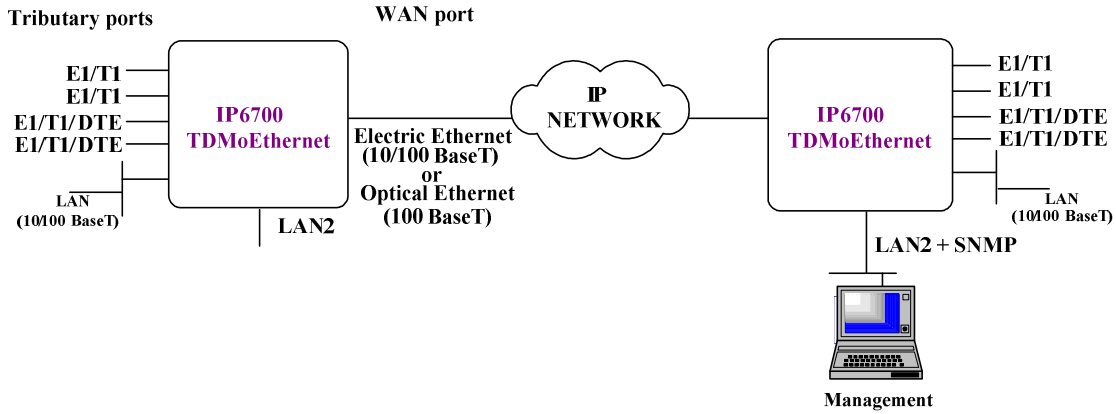

High Speed TDM Application

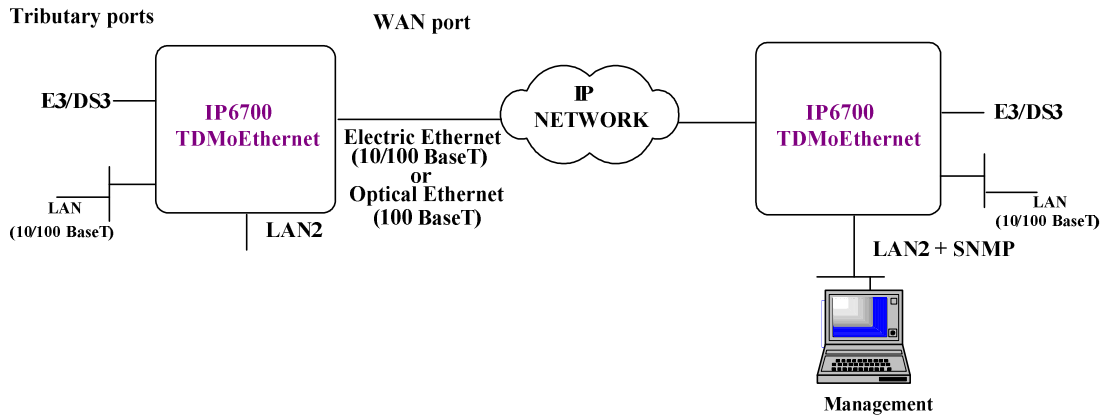

IP6700 Clock Option

To set same clock source to all remote units -----

To set different clock source to different remote units -----

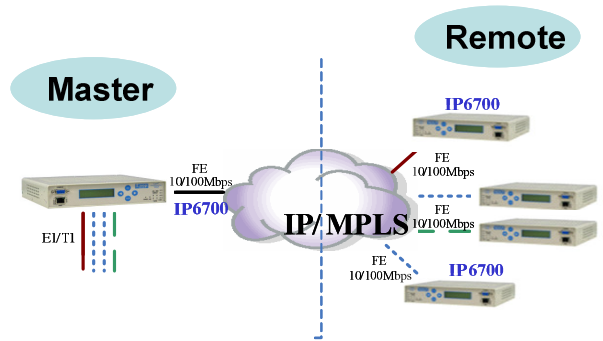
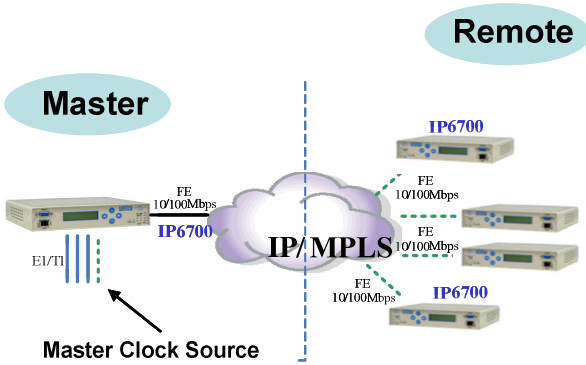

NOTE: If independent clocks are used with T1 signals and the WAN port is transported over a wireless network, a possibility of occasional 1 second pattern loss exists

IP6700 Extension Phone System

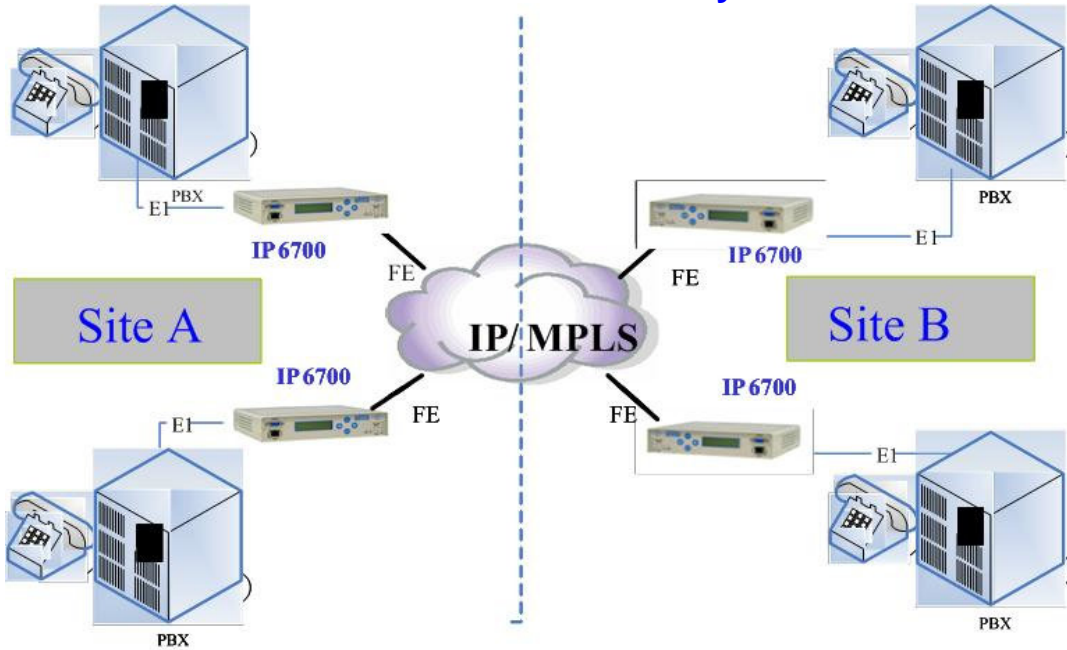

IP6700 on VPN Network

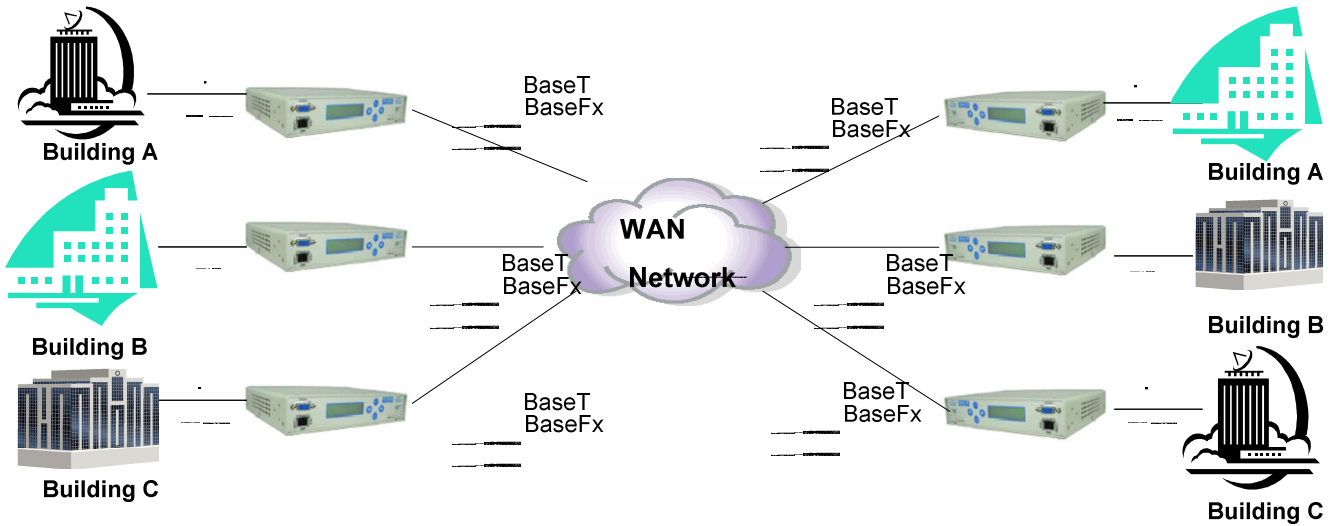

Data Comm for Business, Inc.

2949 CR 1000 E

Dewey, IL 61840

Voice 8004DCBNET (800.432.2638)

Fax 217.897.1331

Info www.dcbnet.com/contact.html

Web www.dcbnet.com