

# SCADA Multidrop Multiplexer

---

## TABLE OF CONTENTS

---

<b>SECTION 1 - DESCRIPTION .....</b>	<b>2</b>
<b>SECTION 2 - SPECIFICATIONS .....</b>	<b>5</b>
<b>SECTION 3 - INSTALLATION .....</b>	<b>7</b>
<b>SECTION 4 - CONTROLS AND INDICATORS.....</b>	<b>12</b>
<b>SECTION 5 - NETWORK MANAGEMENT PORT .....</b>	<b>14</b>
<b>SECTION 6 - INTERFACE SIGNALS AND CABLING.....</b>	<b>24</b>
<b>SECTION 7 - TROUBLESHOOTING .....</b>	<b>29</b>
<b>SECTION 8 - WARRANTY.....</b>	<b>31</b>

Data Comm for Business, Inc.  
PO Box 6329  
Champaign, IL 61826-6329  
(217) 897-6600  
[www.dcbnet.com](http://www.dcbnet.com)

January 6, 2009  
Firmware Version: 3.2

8500111

---

## 1. DESCRIPTION

---

The SCADA Multidrop Multiplexer (SMD) is designed for sharing one multidrop radio, modem or DSU system with 2 or more multidrop polling systems. With the SMD, one multidrop network can support multiple protocols and systems, such as DNP, Modbus, etc. RTUs can be polled on a multidrop system at the same time other polling takes place for load management, automatic meter reading, etc.

Host and remote SMDs can be 1, 4, 8, 16, 24 or 32 port units. Most SCADA applications use 1 and 4 port units. One port units are used on systems that service only a single protocol. Different size SMDs can be mixed on the same multidrop line.

The composite channel of the multiplexer can be synchronous or asynchronous at speeds up to 115.2 Kbps async and up to 128 Kbps sync. Ports on 1 and 4 port units can be set to speeds up to 57.6 Kbps. Ports on 8 – 32 port units can be set up to 38.4 Kbps. All ports are RS232. The device ports can be used with just 3-wires (send, receive and ground) or with full RTS/CTS and Carrier Detect control. Optional RS422 adapters are available for the ports.

The SCADA Multidrop Multiplexer (SMD) sends data from host device ports to the remote units as soon as the data comes into the host ports. All the remote SMDs receive the data. The host SMD is also continually checking the remote SMDs to retrieve any data from remote ports. The SMD unit also keeps together blocks of data coming into the ports. This insures that polling protocols such as Modbus RTU will work successfully with the SCADA Multidrop Multiplexer.

The SMD can also be used to access serial management ports or control power to devices at remote locations. Four port units can be used with DCB EtherBridge units to bridge LAN connections to remote sites.

Setup of the SMD is simple, using a terminal or PC connected to the network management port. Easy to use English command menus are used to set port speeds, unit IDs (if desired), the drop number for the remote multiplexers, sync or async network operation, and control lead timing parameters. The management port can also be used to check system operation, including port activity, link errors, port monitoring, etc. The management port commands are short, simple and comprehensive.

Some features of the SCADA Multidrop Multiplexer include:

- Synchronous or asynchronous composite
- Multiplex over radios, modems, DSUs, etc
- Multiplex multiple separate polling systems
- Use for SCADA RTU control, metering, load management, etc.
- Each port can have a different protocol and application
- One port unit available for single protocol applications
- Each port can be set to a different speed
- Host to remote port speed conversion
- Add remote Ethernet with the DCB EtherBridge
- Access Port function allows direct terminal communication with devices at any remote Drop.
- Remote control power module (APS-01) supported through Access Port function
- Standalone, rackmount or wallmount

Options:

- Built-in 56 / 64 Kbps DSU/CSU
- Built-in wireless modem (1 and 4 port models only)
- DC power options are also available

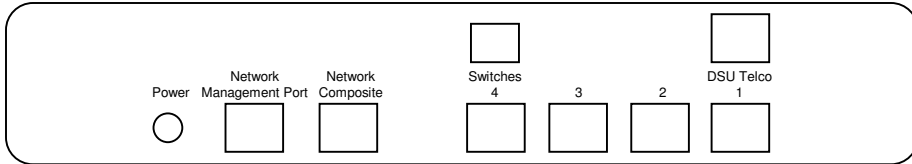
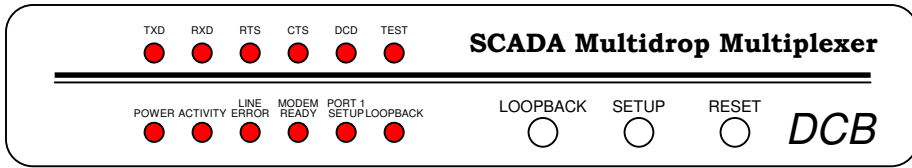

4 Port SMD Multiplexer shown with optional built-in DSU/CSU

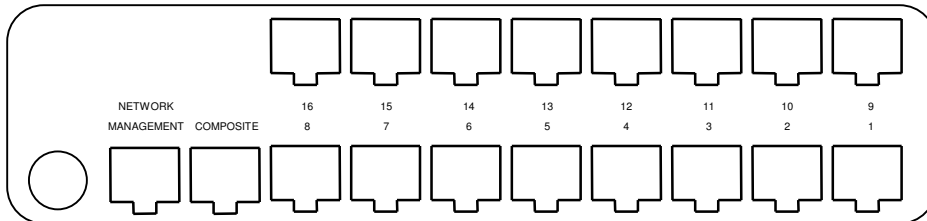
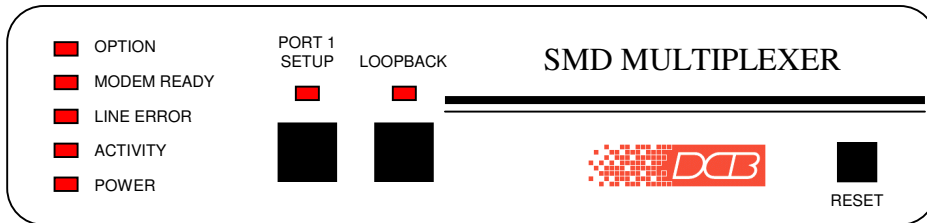

16 Port SMD Multiplexer

---

## 2. SPECIFICATIONS

---

### 2.1 Data Ports

#### Port Speeds

Asynchronous only  
300, 600, 1200, 2400, 4800, 9600, 19,200, or 38,400  
(and 57,600 bps on 1 and 4 port units)

#### Port Rate Selection

Selected per port through network management port control  
with an asynchronous terminal.

#### Interface

CCITT V.24, RS-232D, implemented in RJ-45, 8 position  
connectors. (RS-561 standard physical pin-out used on RJ-45  
connectors)

### 2.2 Composite Port

#### Speed

Synchronous up to 128 Kbps  
Asynchronous from 300 to 115,200 bps

#### Interface

RS-232D, implemented in RJ-45, 8 position connector

### 2.3 Physical / Electrical

10¼" W x 9¾" D x 2½" H (1 thru 16 port models)  
10¼" W x 9¾" D x 4¼" H (24 and 32 port models)  
120 VAC external power supply  
Optional DC and 240VAC power supplies available  
470 ma

### 2.4 Environmental

Operation: -40 to +70° C, 10 to 95% relative humidity  
Storage: -40 to +85° C, 10 to 95% relative humidity

### 2.5 Optional Built-In DSU/CSU Specifications

Compatible with Common Carrier digital signalling  
56 or 64 Kbps  
4 wire digital line  
Can be used as high speed 4 wire line driver in 56K mode

## 2.6 Network Management Port Commands

- Show Port Configuration
- Show Map
- Show Network Status
- Change Port Configuration
- Change Map
- Change Delay Timeout
- Configure Network
- Configure Options
- Configure Radio Modem
- Show / Change mux and port IDs
- Set NMP Password
- Set Access Port disconnect string
- Set Access Port prompt
- Activity Counters
- Zero Activity Counters
- Drop Activity Counters
- Test Tools
  - Capture Access Port
  - Monitor Port Tx
  - Monitor Port Rx
  - NMP Parity
  - Ping Drop
  - Power Port Commands
  - Reset Mux
- Type
- Repeat Last Command
- Disconnect NMP

## 2.7 Other Specifications

- Operating Modes
  - Host or Drop
  - Full or Half Duplex Network Modem
- Front Panel Indicators
  - Power
  - Activity
  - Line Error
  - Modem Ready
  - Port 1 Setup
  - Loopback (disabled)
- Front Panel Switches
  - Loopback (disabled)
  - Setup
  - Reset

---

## 3. INSTALLATION

---

### 3.1 Unpacking

Remove the multiplexer from the shipping container and examine it carefully for external damage. If shipping damage is apparent, notify the shipper immediately.

The following accessories are included with all multiplexers:

- external power supply (AC only)
- manual
- warranty, maintenance contract and repair information
- Modem to Composite cable (black) for connecting the unit to an external modem or DSU/CSU
- Network Management Port cable (green) for connecting the network management port to an asynchronous terminal or PC for configuration
- If your unit has the optional built-in DSU/CSU, a cable is included for connection to the phone line.

### 3.2 Setup

The composite port must be configured properly for the type of link used (Sync or Async). In addition, each device port must have the proper speed settings. This is done using the network management port CN and CP commands (see Section 5).

The default mode for SMD multiplexers is Host. In the Host unit, you must configure the Drop Map. This is what tells the Host which Drops to poll. Use the CM command.

Units used as Drops must be configured as "DROP" using the CO command. Drop numbers can range from 1 to 63. After the drop number is entered, you will have the option to enable Transparent mode. Transparent mode is used during initial deployment of the SMD multiplexers. In transparent mode data is passed directly from device port 1 to the composite port as though the multiplexer was not in the circuit (transparent). NOTE: Port 1 is the only port that is connected in Transparent mode. This allows all of the Drop multiplexers to be installed while maintaining SCADA communication back to the host. After all the remote drops are installed, the Host multiplexer is configured and installed. When the Host starts polling the Drops they automatically switch to multiplexing mode and the system comes on-line using the SMD units.

### 3.3 Using Leased Line Modems

In this section, a reference to modem includes modems or DSU/CSUs for 4-wire leased line installations.

Connect the modems to the phone line and power ON the modems. Confirm the presence of carrier at each modem. If carrier is not detected at both ends, recheck the option settings. If carrier is still not present, check the cable from the telephone line to the modem. If everything is correct and still no carrier call the manufacturer of the modem or contact the telephone company for assistance.

Connect the multiplexer composite port to the modem. A two foot RJ45 to DB-25 male cable connects the composite port of the unit (the RJ45 connector second from the left when viewed from the rear) to the data port of the modem (usually a DB-25 female connector). See Section 6 for cabling information.

Connect the multiplexers to power.

### 3.4 Optional Built-In 56 / 64 Kbps DSU/CSU

The optional DSU/CSU in the 1 and 4 port models is configured using DIP switches accessible from the rear of the unit. See Section 4 for a description and location of these switches. The default settings should be correct for most applications.

In the 8, 16, 24 and 32 port models, the optional DSU/CSU is configured using the CN command. See paragraph 5.4.8.

For line driver applications over customer owned wire (56K only), set one unit for Master Clock (Line Driver 56) and the other unit to Slave Clock (StdClk 56).

### 3.5 Optional Built-In Wireless Modem (1 and 4 port models only)

Your SMD multiplexer with internal wireless modem was configured at the factory to work in most applications. If changes are required to the modem settings, connect a terminal to the multiplexer network management port (See Section 5) and follow the procedure on the next page. User responses are shown in **BOLD**.



AT YOUR COMMAND >> **CR<Enter>**

\*\*\* CONFIGURE NETWORK RADIO - Type ESC ESC to stop  
\*\*\* WARNING: Network DCD is ON

MAIN MENU  
Version 2.44 10-20-2004  
Standard Hop Table  
Modem Serial Number 918-8553

- (0) Set Operation Mode
- (1) Set Baud Rate
- (2) Edit Call Book
- (3) Edit Radio Transmission Characteristics
- (4) Show Radio Statistics
- (5) Edit MultiPoint Parameters
- (6) TDMA Menu
- (8) Chg Password
- (Esc) Exit Setup

Enter Choice

*Make the required changes following the menu prompts. See the DCB-115 manual for options. Type Esc Esc to exit.*

**<Esc><Esc>**

\*\*\* NOTE: If you changed the radio baud rate, enter  
\*\*\* the new rate now, otherwise press ESC.

CONFIGURE NETWORK

-----  
ASYNC MODEM: 57600 BPS  
HALF-DUPLEX  
IGNORE NETWORK DCD

ASYNC rate? [4800/9600/19200/38400/57600/115200] >> **<Esc>**

\*\*\* END CONFIGURE RADIO - Please wait for RESET!

SMD4 SCADA Multi-Drop Mux V3.x ID:

AT YOUR COMMAND >>

### 3.6 Access Port Operation

At the Host, ports can be configured as Access ports. When configured as an Access port, a direct connection is established between that port and the same number port on any active Drop. To use an Access port you may either connect a terminal directly to the port or use the Network Management Port CA# command from the management terminal. In either case you will be prompted for a Drop number. Enter the Drop number that you wish to connect to and you now have a direct connection to that Drop.

The accessed port at the Drop is configured as a data port and can be connected to an equipment console, management or configuration port to allow remote access to the equipment.

### 3.7 Power Port Operation

Drop ports may be configured as Power ports for connection to a DCB APS-01 power control unit. This allows for remote power control of equipment at Drop locations.

The Drop port must be configured as a Power Port (PP) to properly control the APS-01. Use the CP command to configure the port. Four power port commands are available for local testing using the Drop Network Management Port. The commands are ON#, OFf#, CYcle# and SStatus where # is the Power Port number (1-32). The port number is optional after it is entered the first time. The SStatus command will display the current state of all ports configured as Power Ports. These commands are provided for testing during initial installation of the APS-01.

At the Host, power ports are controlled using an Access Port. Therefore, the Host port number corresponding to the Drop Power Port must be configured as an Access Port. To control the Drop Power Port you may either connect a terminal directly to the Host Access Port or use the NMP CA# command from the management terminal. When connected, you will be prompted for a Drop number. Enter the number of the Drop you wish to access followed by a Power Port command (i.e. 1ON to turn power ON at Drop 1). The Drop number is optional after it is entered the first time and all subsequent power port commands will go to that same Drop. To access a different Drop, enter a new Drop number. If you are connected using the CA# command from the NMP port, type Esc Esc to end the port capture.

### 3.8 Cabling

Cabling between the multiplexer and the computer ports or terminal devices is a common source of installation problems. The multiplexer must have data from attached terminal devices or computer ports, as an input on position 6 of the RJ45 connector. Data from the multiplexer to any attached equipment will be transmitted on position 5 of the RJ45 connector. See paragraph 6.1 for position locations on the RJ45 connector. See Section 6 to determine the correct cables for your computer and terminal devices.

### 3.9 Resetting Factory Defaults

The factory default settings for the multiplexer ports are as follows:

Device Ports:

Type	Data
Loop	OFF
Rate	9600

Composite Port:

Modem type	ASYNCR
Rate	9600 bps
Half Duplex	
Ignore Network DCD	

Mode:

1 and 4 port models	8, 16, 24 and 32 port models
Host Mode	Host Mode
DROP polling enabled	PORT polling enabled
Poll timeout: 500 ms	Poll timeout: 25 ms
Poll restart: 2 (x 15 sec)	Remote Response timeout: 500 ms
DCD to Rx data delay: 0 ms	Poll restart: 2 (x 15 sec)
	Maximum CTS allowed: 8
	DCD to Rx data delay: 0 ms

To reset the unit to factory defaults use the **!R** command from the network management port OR perform the following steps using the front panel switches:

1. Depress and hold the SETUP switch then depress and release the RESET switch.
2. Be sure to continue to hold the SETUP switch until the unit completes the reset and the lights return to normal.
3. All port settings should be at the factory defaults. Use the SC (Show Configuration) command to check the settings.

## 4. CONTROLS AND INDICATORS

### 4.1 Switches

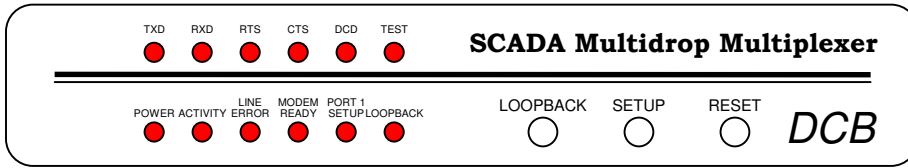

#### 4.1.1 Front Panel Switches (shown with built-in DSU)

Setup – Maps the network management port commands to the terminal attached to data port 1. When Port 1 Setup is active, the indicator is on.

Loopback – Disabled.

Reset – Performs a hardware reset of the multiplexer.

#### 4.1.2 Optional Built-In DSU Switches (1 and 4 port models only)

The DSU switches are located at the rear of the unit. Switch functions are shown in the following table:

Switch	Down	Up
1	56K	64K
2	Slave Clock	Master Clock (56K only)
3	Must Be Down	
4	RTS Normal	RTS Forced ON
5	Normal	Local Loop ON
6	Not Used	

#### NOTE

RTS mode (sw 4) is active in 56Kbps mode only. In 64Kbps mode, RTS is forced on.

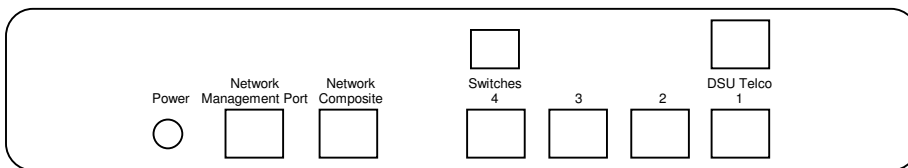

For normal operation with a telephone company line, set the DSU for SLAVE clock timing (switch position 2 DOWN). For in-house line driver applications (56K only), set the host DSU for MASTER timing (switch position 2 UP). The remote unit should remain set for Slave clock.

#### 4.2 Multiplexer Indicators

POWER – ON when the multiplexer has power

##### ACTIVITY

ON – HOST is polling one or more active drops  
DROPPING is receiving polls from the host

FLASHING – if there are no active drops, the ACTIVITY indicator will flash at a rate determined by the poll timeout and restart settings. These are set using the CO command.

OFF – the DROPPING is not being polled.

LINE ERROR – flashes when a data error is detected or when Poll Restart is set to Continuous and there is no response to polls.

##### MODEM READY

ON – Data Carrier Detect is present from the composite link device indicating an active composite link.

OFF – Data Carrier Detect is not present from the composite modem or DSU/CSU indicating a problem with the composite link.

FLASHING – Unit is in Transparent Mode.

OPTION – 8 thru 32 port models only, not used.

PORT 1 SETUP – ON when the network management port functions have been mapped to device port 1 by depressing the front panel switch. To return these functions to the network management port, type BYE or depress the front panel switch again.

LOOPBACK – Disabled

#### 4.3 Optional DSU/CSU Indicators (1 and 4 port models only)

TxD	Flashing	Data is being sent over the link.
RxD	Flashing	Data is being received from the link.
RTS	ON	Forced on or high from the multiplexer.
	OFF	No RTS from the multiplexer.
CTS	Follows RTS	CTS signal to the multiplexer.
DCD	ON	Normal condition.
	OFF	No carrier signal received from the far end.
TEST	ON	Unit is in loopback (DIP switch 5 UP)
	Flashing	Telephone line in loopback.

---

## 5. NETWORK MANAGEMENT PORT

---

### 5.1 Introduction

The Network Management port (NMP) is used to configure the multiplexer for proper operation. This connection must be used to configure the composite and device ports. The NMP can also be used to configure remote multiplexer ports after a link is established between the host and drop sites.

### 5.2 Connections and Setup

Connection to the NMP is made either through a port on the rear of the multiplexer or by using Port 1 Setup.

#### 5.2.1 Port 1 Setup

The easiest way to access the NMP functions is by using a terminal connected to port 1 of the multiplexer. A switch located on the front panel performs this function. See paragraph 4.1.1 for information. This option cannot be used if a printer is connected to port 1.

#### 5.2.2 Dedicated Terminal or PC

The NMP functions are also available through a port on the rear of the unit labeled Network Management Port. To connect a dedicated terminal to this port, use the green cable provided and the appropriate adapter for either a terminal or PC. Set the terminal device for 9600 bps, 8 data bits, no parity, one stop bit and no flow control.

#### 5.2.3 Dedicated Modem

For remote access to NMP functions, a dial-up modem may be connected to the Network Management Port. You must fix the DTE interface speed of the modem at 9600 bps, 8 data bits, no parity and one stop bit. Refer to your modem manual for appropriate setup procedures. Use the appropriate cable from paragraph 6.3.3 for connection.

### 5.3 Using the Network Management port

To activate the NMP, press the ENTER key. When you see **AT YOUR COMMAND >>**, the NMP is active and ready for your commands. Type H <Enter> to display the command set.

### 5.4 Commands

#### NOTE

The commands listed below are for a unit configured as a HOST. Some commands are not available for units configured as DROPS.

#### 5.4.1 Help (H or ?)

<u>COMMAND</u>	<u>LOCAL</u>	<u>REMOTE</u>	<u>PARAGRAPH</u>
Show: Config	SC	RSC#	5.4.2
Drop/Port Map	SM		5.4.3
Network	SN		5.4.4
Change: Port Config	CP	RCP#	5.4.5
Drop Map	CM	RCM#	5.4.6
Delay Timeout	CD	RCD#	5.4.7
Config Network	CN		5.4.8
Config Options	CO		5.4.9
Config Radio	CR		5.4.10
Set ID	ID	RID#	5.4.11
Set Password	PW		5.4.12
Set AP Disconnect	SD		5.4.13
Set AP Prompt	SP		5.4.14
Activity Counters/Zero	AC/Z	RAC#/RZ#	5.4.15
Drop Activity Counters	DA/Z		5.4.16
Test Tools	TT		5.4.20
Type	TY	RTY#	5.4.17
Repeat Last Command	*		5.4.18
Disconnect NMP	BYE		5.4.19

This Help screen shows the choice of commands available. The commands allow you to display the selected options (Show network and configuration), configure the multiplexer (Configure ports and Set ID), and perform many different diagnostic functions such as monitor data, perform loopbacks, show port activity and other useful tests.

#### 5.4.2 Show (Unit) Configuration

The Show Config (SC) command shows the current network, mode, and device port configuration settings for either the local or the remote unit. A drop number is required with the RSC# command from the host. Port numbers may be included with this command to limit the port display. If no port numbers are included, settings for all device ports are shown. Use this command to verify proper unit configuration.

#### **NOTE**

Several commands allow device port numbers or port number ranges to be included on the command line. When port numbers are included, the syntax is as follows:

(Command)1	Port 1
(Command)1,2,4	Ports 1, 2 & 4
(Command)2-4	Ports 2 thru 4

#### 5.4.3 Show Drop / Port Map

The Show Drop Map (SM) command displays a list of all drops mapped to the host. Up to 63 drops can be mapped to a single host. Only mapped drops are polled by the host. The drop map is entered using the CM command.

At a Drop, the command displays the Drop port mapping to the Host. The port map is entered using the CM command.

#### 5.4.4 Show Network (Configuration)

The Show Network (SN) command displays the current network (composite port) configuration. Sync or async, async speed, full or half duplex and modem DCD settings are displayed.

#### 5.4.5 Change Port Configuration

The Change Port Config (CP / RCP#) command sets the loopback, rate and port type for each device port. With optional firmware, ports can be set to 8 data bits plus EVEN or ODD parity.



At the Host, port type can be Data port or Access port. See paragraph 3.6 for a description of Access Port operation. In units with 8 or fewer ports, a port can also be configured as a Bridge port. Bridge port configuration is required when a DCB EtherBridge is connected to the Host port.

At a Drop, port type can be Data port, Access port, Power port or Bridge port. The Bridge port setting is required when a DCB EtherBridge is connected to the Drop port. See paragraph 3.7 for a description of Power Port operation.

Follow the prompts and examples on the screen to select the port(s) and parameter(s) you wish to change. One or more ports may be set with a single command by selecting a range of port numbers. The factory default setting is loop off, 9600 bps, data.

The RCP# command may be used from the host to set device ports on drops. An active drop number (#) is required. If no drop number is supplied, the last drop accessed by any remote command will be used.

#### 5.4.6 Change Drop / Port Map

At the Host, use the CM command to enter or edit the drop map. Valid drop numbers are 1 – 63. Only drops that are mapped will be polled for data by the host.

At a Drop, the command is used to enter or edit the port map. Drop ports may be mapped to any Host port. Valid Host port numbers are 1 – 32 and each Host port can appear only once in the port map.

The port map can also be changed from the Host using the RCM# command where # is a valid Drop number.

#### 5.4.7 Change Delay Timeout

At the HOST and DROP

This command (CD/RCD#) is used to change two device port timeout parameters, DCD to Rx data delay and DCD holdover delay. These delays may be adjusted to insure data block integrity.

DCD to RX data delay can be set from 0 to 250ms. This is the time between Port DCD being asserted and data being sent out the port to the attached device. For example, if you are using a 202T modem off a drop port, you may want to set the DCD to RxD delay to match the modem RTS/CTS delay and use the SMD DCD signal to drive the modem RTS signal. If this parameter is set to zero (0), port DCD is forced ON.

If DCD to RxD is NOT set to zero (forced on), the DCD Holdover delay may be set to a value between 2 and 250ms. This will hold port DCD on for the designated time after the port buffer empties. This can help insure that all data gets to the attached device.

Use RCD# to change drop timeouts from the host.

At a DROP

At a Drop, there are two additional parameters that can be changed. They are Buffer Clear timeout and Port buffer Smart Discard.

Buffer Clear timeout. can be set from 100 ms to 10 seconds. The default setting is 2.5 seconds. If a host poll is not received within the timeout period after a block is buffered, that block is discarded. It is recommended that the drop Buffer Clear timeout be set to approximately the same value as the host computer poll timeout.

In addition, you can enable or disable Port buffer Smart Discard. When Port buffer Smart Discard is enabled, all buffered port data is discarded when new data arrives from the host for that port. This prevents old port data from going to the host when a new poll arrives.

#### 5.4.8 Configure Network

The Configure Network command (CN) allows configuration of the multiplexer composite port for asynchronous or synchronous operation, full or half duplex and ignore modem DCD (yes/no). In 8 thru 32 port models, the command is also used to set the optional DSU/CSU mode of operation.

When set for HALF DUPLEX, network RTS toggles and the mux waits for CTS before sending. It may also wait for DCD (see below).

If set for HALF DUPLEX and IGNORE DCD=YES, then the host and drop toggle network RTS and wait for CTS before sending. DCD is not tested when blocks are received on the network port.

If set for HALF DUPLEX and IGNORE DCD=NO, then the host and drop wait for DCD to turn OFF before they turn RTS ON to send a block. In addition, DCD must be ON when an RX block arrives at the network port.

When set for FULL DUPLEX, network RTS is always ON and network CTS is ignored.

If set for FULL DUPLEX and IGNORE DCD=YES, then the host sends whenever it is ready to send a poll, and the drop responds immediately when it is polled. In addition DCD is not tested when blocks are received on the network port.

If set for FULL DUPLEX and IGNORE DCD=NO, then the host and drop check for DCD ON when a new block begins. If DCD is OFF when a new block starts, the block is ignored.

#### 5.4.9 Configure Options

The Configure Options (CO) command configures the SMD as either HOST or DROP.

If HOST is selected, the following parameters may be set:

Enable Port Polling (Y/N) Port polling may increase your systems efficiency if you have 8 or more drops or an SMD 8 or larger unit at the host.

Poll Timeout (ms) – the amount of time the host will wait for a response from a drop. After seven polls with no response, the drop is removed from the poll sequence until the poll restart timer expires.

If Port Polling is enabled, a Remote Response timeout can also be set. After the SMD Host sends your data to a Drop port, the Remote Response timeout is the number of milliseconds the Host keeps asking the drops for the response data. This should be set to a value less than or equal to the host computer timeout.

Poll Restart time (n x 15 sec) – every n x 15 seconds, the host will re-poll timed-out drops and attempt to restart them. Enter 0 (zero) to disable or C for continuous polling.

Maximum port CTS allowed [1-32] (8 thru 32 port models only)

If DROP is selected, the following parameters may be set:

Drop number (1 – 63)

Enable Transparent mode (Y/N) See paragraph 3.2.

#### 5.4.10 Configure Radio (1 and 4 port models only)

The Configure Radio command (CR) establishes a direct connection between the network management port and the optional built-in wireless modem. The command is used to change configuration settings in the wireless modem. See paragraph 3.5.

#### 5.4.11 Set ID

The Set ID (ID/RID#) command allows you to set or change the local multiplexer (name or location) and device port identifiers. IDs can be a maximum of 15 characters in length. Pressing <Enter> with no entry will leave the ID unchanged. This is for documentation only and is not required for proper operation of the multiplexer. Use the RID# command to set/change IDs of drop multiplexers from the host.

#### 5.4.12 Set Password

Use the Set Password (PW) command to set a password for access to the network management port. The password may be up to 15 characters long and is case sensitive.

To clear the password, type DELETE at the PW prompt or reset the unit to defaults as described in paragraph 3.6.

#### 5.4.13 Set Access Port Disconnect string (Host only if Access port configured)

The SD command is used to set the disconnect string used by Access ports. The disconnect string is used to disconnect from the current drop. The default is ^D^D^D (Ctrl D). To change the disconnect string, type SD and enter the new characters. Control (Ctrl) characters may be entered by holding the Ctrl key and pressing the character key. If no Access ports are configured, this command is not available.

#### 5.4.14 Set Access Port Prompt (Host only if Access port configured)

This command (SP) is used to set the Access port prompt. This is the prompt that you will see if a terminal is connected to a host Access port or if the CA# command (see paragraph 5.4.22) is used to connect to an Access port from the Network Management Port. The default is "Access Drop#". To change the prompt, type SP and enter the new prompt. If no Access ports are configured, this command is not available.

To use an Access port you must connect a terminal to that port on the Host multiplexer either directly or by using the CA# command. At the prompt, you must enter a Drop number (1-63). You will then have a direct connection from the Host port to the same port number on the drop. For example, if you define port 4 as an Access port and connect your terminal to port 4, then access Drop 2, you will be connected to whatever device is connected to port 4 on Drop 2. Port IDs can be set to help document what type of device is connected to which port.

#### 5.4.15 Activity Counts / Zero

The Activity Counts (AC / RAC#) command shows transmit and receive data statistics for all ports. The data are presented in terms of blocks of information sent and received by the network and each device port. Error counts are also shown. A range of ports may be included with this command to reduce the number of ports shown.

The Z and RZ# commands are used to zero the counters so that current activity can be monitored.

#### 5.4.16 Drop Activity Counters

The DA command displays the following report.

At the **HOST:**

DROP ACTIVITY

```

-----
      Drop   Poll   Poll   Drop   Resp   Drop
D#  Polls   Resp   Fail   Inact   Time   Status
--  -
01  38860  38859     1     0     4  ACTIVE
15   194     0   194   182     0 INACTIVE!

```

NOTE: Use the Z command to Zero Counters.

At a **DROP:**

DROP ACTIVITY

```

-----
      Poll   Drop
D#  Polls   Intvl  Status
--  -
01  26546    10  RECEIVING POLLS

```

NOTE: Use the Z command to Zero Counters.

#### 5.4.17 Type

The Type (TY) command displays information about the local multiplexer including firmware version, number of ports and multiplexer ID. The Remote Type (RTY#) command is used at the host to display similar information about a drop multiplexer.

#### 5.4.18 Repeat Last Command

To repeat the last command, simply press the \* key. This is handy for repeating screens of constantly changing data.

#### 5.4.19 Disconnect NMP

The BYE command toggles the CTS output from the Network Management port. This is used to disconnect equipment such as dial-up modems or the DCB Access Switch.

#### 5.4.20 Test Tools

The Test Tools (TT) menu summarizes the test and troubleshooting commands. These commands are listed separately to reduce the clutter in the main help list, but are always available from the command prompt.

<u>COMMAND</u>	<u>LOCAL</u>	<u>REMOTE</u>	<u>PARAGRAPH</u>
Capture AP Port	CA#		5.4.21
Monitor Port Tx	MT#		5.4.22
Monitor Port Rx	MR#		5.4.22
NMP Parity	P		5.4.23
Ping DROP	PING#		5.4.24
Power Port Commands	ON#		5.4.25
	OFF#		
	CYCLE#		
	STATUS		
Reset Mux	RESET	RRESET#	5.4.26

#### 5.4.21 Capture Access Port (Host only if Access port configured)

This command (CA#) is used from the Network Management Port to connect to an Access port. A valid Access port number must be included on the command line. This allows the NMP terminal to use the Access port to connect to a remote device. See paragraphs 3.6 and 3.7. If no Access ports are configured, this command is not available.

#### 5.4.22 Monitor Port TX or RX

The Monitor Port TX (MT#) command monitors data transmitted from the selected device port to the corresponding port of the remote multiplexer. The Monitor Port RX (MR#) command monitors data received by the selected port from the corresponding port of the remote multiplexer. A local port number must be included on the command line.

Using these commands on an active line may cause errors when using time sensitive protocols. Use the commands as a quick check to see if data are being sent over the link. Do not try to use these commands as a data line monitor.

When port monitor is active, two ESC characters are required to end the test.

#### 5.4.23 NMP Parity

The NMP Parity command (P) sets the parity for the network management port. The factory default is SPACE (8,N,1).

#### 5.4.24 Ping DROP / HOST

From the host, the PING# command pings a drop multiplexer and displays the response time in milliseconds. From a drop, the PING command displays the response time from the host.

#### 5.4.25 Power Port Commands (Drop only if Power port configured)

Four commands are available at Drops to troubleshoot and test Power ports. They are: ON# (turns power on), OFF# (turns power off), CYCLE# (cycles power as determined by the current state and the cycle time parameter) and STATUS (displays current status of all Power ports). The # indicates the Power port number (1-4). See paragraph 3.7.

#### 5.4.26 Reset Mux

The Reset Mux (RESET) command performs a local multiplexer reset. The RRESET# command can be used from the host to reset a drop multiplexer.

---

## 6. INTERFACE SIGNALS AND CABLING

---

### 6.1 Connector Location and Pin Reference

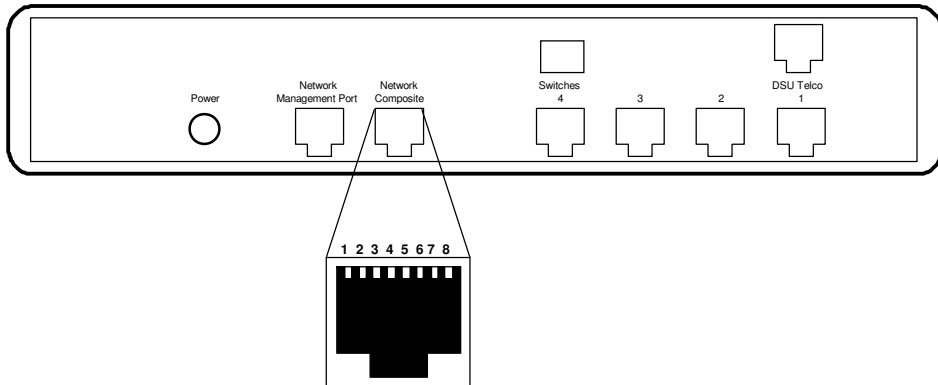

Multiplexer Rear Panel and RJ-45 Jacks

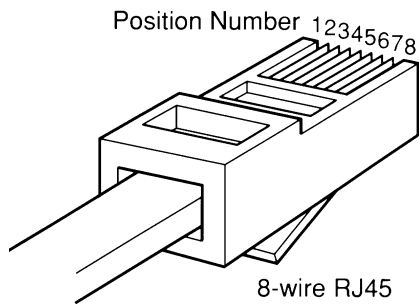

RJ-45 Plug Positions



## 6.2 Port Interface

### 6.2.1 Composite Port (RJ-45)

<u>Pin</u>	<u>Signal</u>	<u>In/Out</u>
1	Receive Clock	IN
2	Transmit Clock	IN
3	Data Carrier Detect	IN
4	Signal Ground	
5	Transmit Data	OUT
6	Receive Data	IN
7	Request to Send	OUT
8	Clear to Send	IN

### 6.2.2 Device Ports (RJ-45)

<u>Pin</u>	<u>Signal</u>	<u>In/Out</u>
1	Data Set Ready	OUT
2	Data Carrier Detect	OUT
3	Busy	IN
4	Signal Ground	
5	Receive Data	OUT
6	Transmit Data	IN
7	Clear to Send	OUT
8	Request to Send	IN

### 6.2.3 Network Management Port (RJ-45)

<u>Pin</u>	<u>Signal</u>	<u>In/Out</u>
1	Not Used	
2	Not Used	
3	Data Terminal Ready	IN
4	Signal Ground	
5	Receive Data	OUT
6	Transmit Data	IN
7	Clear to Send	OUT
8	Request to Send	IN

### 6.2.4 Optional Built-In DSU Interface (RJ-48S)

<u>Pin</u>	<u>Signal</u>	<u>In/Out</u>
1	Transmit Data	OUT
2	Transmit Data	OUT
7	Receive Data	IN
8	Receive Data	IN

### 6.3 Cables

#### 6.3.1 Composite Port to external Modem or DSU/CSU

A two foot composite to modem cable is included with each multiplexer. The pinout is as follows:

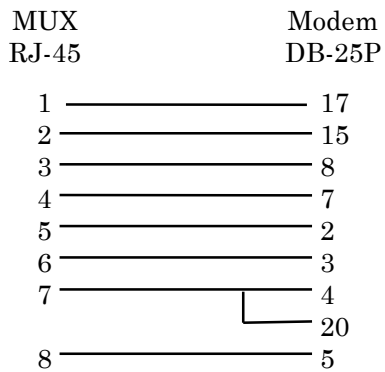

#### 6.3.2 Device Ports to Host Computer

Configured as DTE

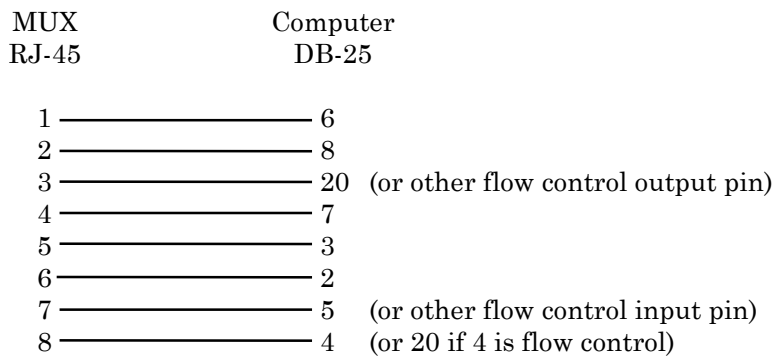

### 6.3.2 Device Ports to Host Computer, continued

Configured as DCE

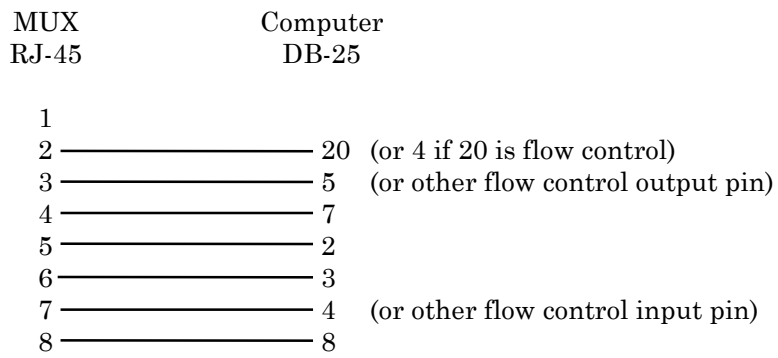

To a PC Com Port

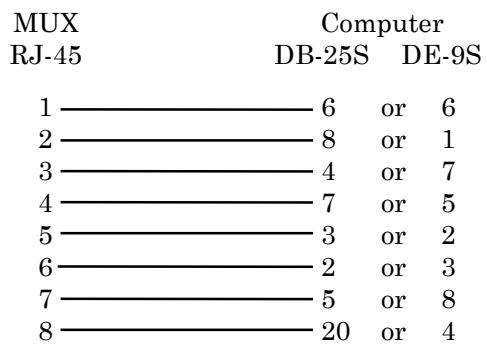

### 6.3.3 Network Management Port

To a TERMINAL

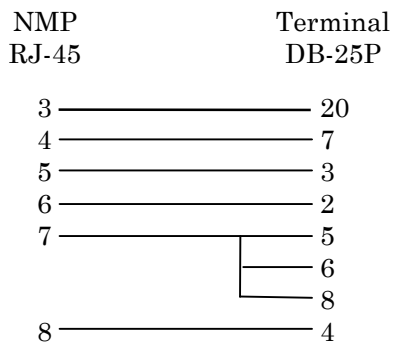

To a PC using terminal emulation

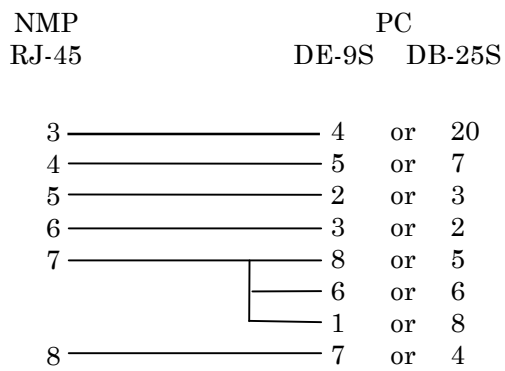

To a dial-up MODEM for remote access

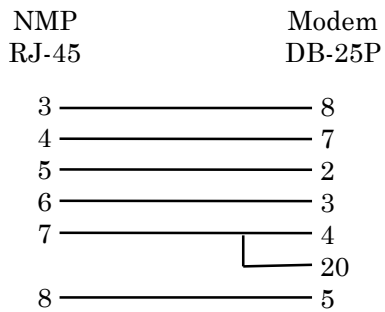

---

## 7. TROUBLESHOOTING

---

### 7.1 General Approach

When troubleshooting problems, a rational plan can save you many hours of frustration. The following is a brief outline of standard troubleshooting procedures.

1. Gather the facts to determine the exact nature of the problem.
2. Draw a picture of the system showing the equipment at both the host and remote ends and the phone lines or in-house wiring. Use this as a reference to note your observations, test steps and test results. A picture keeps you focused and often saves duplicate effort.
3. Record the front panel indications before changing anything. This is an important part of fact gathering
4. If you change anything, change only one thing at a time.
5. Use the built-in test functions, especially the loopback tests and record your results.

### 7.2 Loopback Tests

It is best to begin loopback testing at the remote terminal and work toward the host. If all the loopbacks are successful, the data communications equipment and the terminal are working correctly.

Put the remote multiplexer port in loopback and have someone type alpha characters on the keyboard of the affected terminal. If the characters appear correctly on the screen, the port is working. Next loop the associated port of the host multiplexer. If characters again appear correctly, the communications link and the ports on both multiplexers are working correctly. The problem then is with the host computer port or the cable between the host computer and the multiplexer.

Port loopbacks can be turned on and off from the Network Management port of the multiplexer. If a NMP terminal is not available, port loopback can be enabled using the Port 1 Setup function of the remote multiplexer

### 7.3 Installation Troubleshooting, Modems or DSUs

First, set up the Modems or DSUs without connecting the multiplexers. If DSUs are used they should be set to constant carrier, also called forced Request To Send, or constant RTS.

Carrier Detect should be ON at both locations.

### 7.4 Installation Troubleshooting, Multiplexers

Before trying terminals, make sure the multiplexers are able to “see” each other. Use the RTY command to verify a response from the remote multiplexer. If you get a correct response to RTY, the link is up and the multiplexers are communicating.

### 7.5 Installation Troubleshooting, Terminals

Terminal problems typically fall into four categories:

1. The terminal or printer gets no data
2. The terminal or printer gets “garbage” data
3. Blocks of data are lost
4. Terminals or printers seem to “hang”.

When a terminal gets no data, check to see the cables are wired correctly and that flow control is set properly.

If the terminal gets “garbage” data, check the speeds of the host and remote multiplexers, the terminal and the computer ports to make sure they match.

### 7.6 Assistance

If you need assistance troubleshooting your system, contact DCB customer support at (217) 897-6600 between 8:00 am and 5:00 pm central time Monday through Friday.

---

**8. WARRANTY**

---

DCB multiplexers are warranted to be free of defects in materials and workmanship for two years. Data Comm for Business will repair or replace any equipment proven to be defective within the warranty period. All warranty work is F.O.B. Dewey, IL. This warranty is exclusive of abuse, misuse, accidental damage, acts of God or consequential damages, etc. DCB liability shall not exceed the original purchase price.

All equipment returned for repair must be accompanied by a Returned Material Authorization (RMA) number. To receive an RMA number, call (217) 897-6600 between the hours of 8 AM and 5 PM central time. Equipment must be shipped prepaid to DCB and will be returned at DCB's expense.

Ship returned items to:

Data Comm for Business  
2949 County Road 1000E  
Dewey, IL 61840  
ATTN: your RMA number

Data Comm for Business, Inc.  
PO Box 6329  
Champaign, IL 61826-6329

Tel (217) 897-6600  
Fax (217) 897-1331