

APS-01

TABLE OF CONTENTS

SECTION 1 - DESCRIPTION..... 2

SECTION 2 - SPECIFICATIONS 3

SECTION 3 - INSTALLATION..... 4

SECTION 4 - OPERATION 5

SECTION 5 - CONTROLS AND INDICATORS..... 6

SECTION 6 - RS-232 INTERFACE DESCRIPTION..... 7

SECTION 7 - WARRANTY..... 8

Data Comm for Business, Inc.
PO Box 6329
Champaign, IL 61826-6329
(217) 897-6600
www.dcbnet.com

October 7, 2004
Rev. A

1. DESCRIPTION

The Access Power Switch controls AC power to any remote equipment. When used with the DCB Access Switch, it allows the equipment to be turned on, off or power cycled from any remote PC or terminal. Easy Access Switch configuration provides options for default condition (on or off) and power cycle time.

The APS-01 also provides power status back to the Access Switch so the remote operator knows if power to the controlled device is on or off. If primary AC power to the controlling Access Switch is lost, the APS-01 keeps power on to the load. This fail safe feature protects file servers and communications equipment from power disruption caused by wiring changes and equipment replacements.

The DCB Access Switch allows RS-232 control ports and power control ports to be mixed on the same incoming remote modem.

2. SPECIFICATIONS

2.1 Ports

One AC Power port
One RS-232 control port

2.2 Indicators

AC Power on
Load Power on

2.3 Environmental

Operation: 0 to 65° C, 10 to 85% relative humidity
Storage: -40 to 85° C, 10 to 85% relative humidity

2.4 Physical / Electrical

1.5" x 5.75" x 5.5"
120 or 240VAC, 10 Amps max.
Fuse: 250V 10A, Type ABC 10

3. INSTALLATION

3.1 Unpacking

The following is included with each APS-01:

- APS-01 power control module
- Cable for attaching APS-01 to DCB Access Switch
- Manual
- Information regarding warranty, maintenance contracts and repair

3.2 Location

Place the APS-01 in a clear area where you can reach the rear panel to connect the cables. The APS-01 must be connected to a properly grounded 120 VAC outlet. The power cord length is about 5 feet.

3.3 Setup for use with the DCB Access Switch

The APS-01 Normal/Inverted switch must be in the NORMAL position (IN). See Section 5.

The Access Switch must be properly configured for the APS-01 to operate properly. Ports connected to an APS-01 must be configured as POWER ports. Refer to Section 5 of your Access Switch manual. Use the Configure Port (CP) and Set Port ID (ID) commands.

3.4 Connection to an Access Switch

Connect the black RJ-45 line cord (supplied) between the APS-01 RS-232 port and the Access Switch output port that you configured above. Connect the device to be controlled to the AC receptacle on the rear of the APS-01.

3.5 Connection to other controlling devices

If a controlling device other than the DCB Access Switch is used, see the RS-232 interface description in Section 6.

4 OPERATION

4.1 Access Switch Commands

All commands must be preceded by the Access Switch port name (ID) or port number.

<u>Command</u>	<u>Action</u>
<space>ON	Turns power on to load device
<space>OFF	Turns power off to load device
<Enter>	Returns power status (on or off)
<space>CYcle	Cycles power to load device for the specified time.

5. CONTROLS AND INDICATORS

APS-01 Rear View

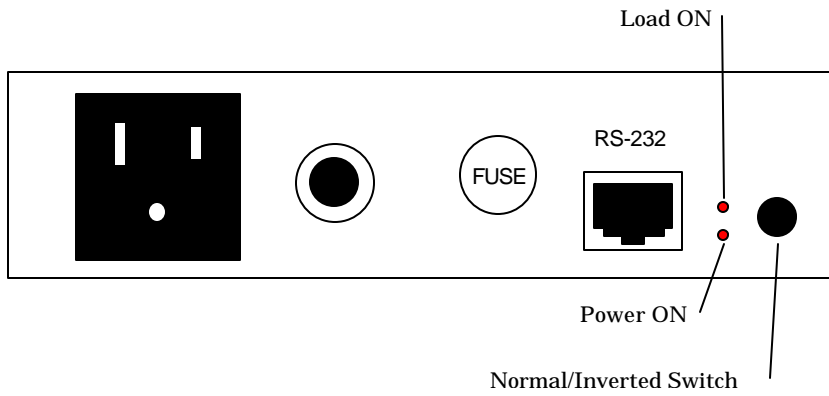

For use with the DCB Access Switch, the Normal/Inverted switch must be in the depressed position (IN). When OUT, the function of the Control input is inverted. See Section 6.

6. RS-232 INTERFACE DESCRIPTION

6.1 Connector Pin Reference

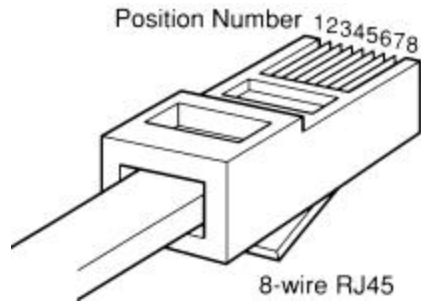

RJ-45 Plug Positions

6.2 RS-232 Port (RJ-45)

<u>Pin</u>	<u>Function</u>
1	+12V IN/OUT
2	Control IN
3	Status OUT
4	Ground
5	Not Used
6	Not Used
7	Not Used
8	+12V IN/OUT

NOTE

Pins 1 and 8 are shorted internally. One of these pins must have +12v for the Status signal to work properly.

6.3 Function Table

Normal / Inverted Switch	Control Input	Load	Status Output
IN	L	OFF	L
Normal	H	ON	H
OUT	L	ON	H
Inverted	H	OFF	L

7. WARRANTY

All DCB products are warranted to be free of defects in materials and workmanship for one year. Data Comm for Business, Inc. will repair or replace any equipment proven to be defective within the warranty period. All warranty work is F.O.B. Dewey, IL. This warranty is exclusive of abuse, misuse, accidental damage, acts of God or consequential damages, etc. DCB liability shall not exceed the original purchase price.

All equipment returned for repair must be accompanied by a Returned Material Authorization (RMA) number. To receive an RMA number, call (217) 897-6600 between the hours of 8 AM and 5 PM central time. Equipment must be shipped prepaid to DCB and will be returned at DCB's expense.

Ship returned items to:

Data Comm for Business
2949 CR 1000E
Dewey, IL 61840

Data Comm for Business, Inc.
PO Box 6329
Champaign, IL 61826-6329

Tel (217) 897-6600
Fax (217) 897-1331
Email support@dcbnet.com