



Loop-V 4200 9-Port MuxMaster/ Wideband IAD – CSU/DSU, E1/T1 Converter, & DACS User's Manual

LOOP TELECOMMUNICATION INTERNATIONAL, INC.

8F, NO. 8, HSIN RD.

SCIENCE-BASED INDUSTRIAL PARK

HSINCHU, TAIWAN

Tel: +886-3-578-7696

Fax: +886-3-578-7695

© 2003 Loop Telecommunication International, Inc. All rights reserved.

Loop-V is a trade mark of Loop Telecommunication International, Inc.

P/N: 51.LV4200.100

07/2003 Version 7.0

TABLE OF CONTENTS

1.	PRODUCT DESCRIPTION.....	1-1
1.1	Overview.....	1-1
1.2	Physical Description	1-1
1.3	Applications	1-2
1.3.1	As an ICSU	1-2
1.3.2	As a one-to-one E1 to T1 Converter	1-3
1.3.3	As a One-to-Two E1 to T1 Converter.....	1-4
1.3.4	As a Four-to-Five E1 to T1 Converter.....	1-5
1.3.5	As an E1 or T1 DACS	1-6
1.3.6	As a Network Access Device for Data	1-7
1.3.7	As an ATM Frame Relay Transport Device	1-8
1.3.8	As a Router Transport Device.....	1-9
1.3.9	As a Drop-and-Insert Unit for Voice and Data	1-10
1.3.10	As a Wireless Base Station Signal Multiplexer	1-11
1.3.11	As a Full Channel Bank	1-12
1.3.12	As a Combined Network Access and Management Channel Access Device	1-12
1.4	Specifications.....	1-13
2.	INSTALLATION.....	2-1
2.1	Site Selection.....	2-1
2.2	Mechanical and Electrical Installation.....	2-2
2.2.1	Mechanical Installation.....	2-2
2.2.2	Electrical Installation	2-3
2.3	Terminal Connection.....	2-4
2.4	Configuration Setting.....	2-5
2.4.1	Hardware Configuration Setting.....	2-5
2.4.2	Software Configuration Setting.....	2-5
2.4.3	Replacement of Plug-in Card.....	2-5
3.	OPERATION	3-1
3.1	Quick Start for Loop-V 4200 E1/T1 Converter/TSI.....	3-1
3.2	Power On.....	3-1
3.3	Self-Test	3-1
3.4	Using Front Panel.....	3-1
3.5	Review of Default Settings	3-1
3.6	Line Interface Selection	3-1
3.7	Line	3-1
3.8	Map Setup	3-2
3.9	Using Terminal.....	3-2
3.10	System Operation	3-2
3.10.1	Date.....	3-2
3.10.2	Master Clock	3-2
3.10.3	Console Port	3-3
3.10.4	Menu Lock	3-3
3.10.5	Logon, Logoff, and Password	3-3
3.11	Configuration	3-3
3.12	Time Slot Interchange (Digital Access Cross-Connect)	3-3
3.13	Alarms and Reports.....	3-4
3.13.1	Alarms.....	3-4
3.13.2	Report	3-5
3.14	Requesting Report.....	3-7
3.15	LED Operation.....	3-7
3.16	Bantam Jack.....	3-8
3.17	Error Messages	3-9
3.18	Embedded SNMP Agent	3-10
3.19	Inband Management.....	3-10

Loop-V 4200 MuxMaster User's Manual

3.20	Port Backup	3-11
3.21	Verifying Loop-V 4200 Operations	3-11
	3.21.1 Quick Test	3-12
	3.21.2 Substitution	3-12
	3.21.3 Using Loopback Plugs	3-12
4.	FRONT PANEL OPERATION	4-1
4.1	Port Menu	4-2
	4.1.1 DTE PORT	4-2
	4.1.2 E1 PORT	4-2
	4.1.3 T1 PORT	4-2
	4.1.4 MDSL PORT	4-2
	4.1.5 QFXS PORT	4-3
	4.1.6 QFXO PORT	4-3
	4.1.7 ROUTER PORT	4-3
	4.1.8 T1 ATM/ FR PORT	4-3
	4.1.9 E1 ATM/ FR PORT	4-3
4.2	CONTROLLER Menu	4-4
	4.2.1 IP	4-4
	4.2.2 DATE	4-5
	4.2.3 INFO	4-5
	4.2.4 TSI-MAP	4-6
	4.2.4.1 DTE PORT	4-6
	4.2.4.2 E1 PORT	4-6
	4.2.4.3 T1 PORT	4-6
	4.2.4.4 MDSL PORT	4-7
	4.2.4.5 QFXS PORT	4-7
	4.2.4.6 QFXO PORT	4-7
	4.2.4.7 ATM/T1 PORT	4-8
	4.2.4.8 ATM/E1 PORT	4-8
	4.2.4.9 Inband Management	4-8
	4.2.4.10 TSI-MAP SETUP	4-9
	4.2.5 MCLK	4-10
	4.2.5.1 MASTER CLOCK	4-10
	4.2.5.2 SECOND CLOCK	4-10
	4.2.5.3 CURRENT ACTIVE CLOCK	4-10
	4.2.5.4 RECOVER	4-10
	4.2.5.5 STATUS	4-11
4.3	ALARM	4-11
	4.3.1 QUEUE	4-11
	4.3.2 SETUP	4-11
	4.3.3 CLEAR	4-12
4.4	STATUS	4-12
4.5	Miscellaneous	4-12
	4.5.1 Lock	4-12
	4.5.2 MSG Code	4-13
	4.5.3 RESET	4-13
	4.5.4 Console Port	4-13
	4.5.4.1 BAUD Rate	4-13
	4.5.4.2 Data	4-13
	4.5.4.3 STOP	4-13
	4.5.4.4 PARITY	4-14
	4.5.4.5 XONOFF	4-14
	4.5.5 Store	4-14
	4.5.5.1 Store	4-14
	4.5.5.2 Retrieve	4-14
5.	TERMINAL OPERATIONS	5-1
5.1	System Configuration	5-1
5.2	Information Summary	5-2

Loop-V 4200 MuxMaster User's Manual

5.3	System Setup	5-2
5.4	Password Setup.....	5-6
5.5	System Alarm Setup.....	5-7
5.6	Firmware Download.....	5-7
5.7	Firmware Upload	5-8
5.8	Firmware Download/ Upload Procedure.....	5-9
5.9	Configuration Download/ Upload.....	5-12
5.9.1	Download Configuration.....	5-12
5.9.2	Upload Configuration	5-13
5.10	Store/ Retrieve Configuration	5-14
5.10.1	Retrieve Configuration	5-14
5.10.2	Store Configuration	5-14
5.11	Configuration Download/ Upload Procedure	5-15
6.	Appendix A: Multicast/ Broadcast and Backup	6-1
7.	Appendix B: Channel Bank with digital Monitoring Function.....	7-1
8.	Appendix C: 1 : 1 Line Protection.....	8-1

LIST OF TABLES

Table 2- 1 Power Connector	2-3
Table 2- 2 Console Port	2-4
Table 2- 3 Ethernet Port.....	2-4
Table 2- 4 Alarm Relay Connector.....	2-4
Table 2- 5 Default Software Configuration.....	2-6
Table 3- 1 Console Port Setting.....	3-3
Table 3- 2 Alarm Type Table	3-5
Table 3- 3 Performance Parameter List - T1	3-5
Table 3- 4 Performance Parameter List - E1	3-6
Table 3- 5 Performance Report Options.....	3-6
Table 3- 6 Front and Back Panel LED Table	3-7
Table 3- 7 Error Message	3-9

LIST OF FIGURES

Figure 1- 1 Pictorial of Loop-V 4200 MuxMaster Series Products.....	1-1
Figure 1- 2 As an ICSU.....	1-2
Figure 1- 3 As a one-to-one E1/T1 Converter	1-3
Figure 1- 4 As a One-to-One E1/T1 Converter plus Data	1-3
Figure 1- 5 As a One-to-Two E1/T1 Converter.....	1-4
Figure 1- 6 As a Four-to-Five E1/T1 Converter	1-5
Figure 1- 7 As a 8-Line E1 or T1 DACS	1-6
Figure 1- 8 As a Data Access Device for Digital Networks.....	1-7
Figure 1- 9 As an ATM Frame Relay Transport Device.....	1-8
Figure 1- 10 As a Router Transport Device	1-9
Figure 1- 11 As a Drop-and-Insert with Voice and Data Access	1-10
Figure 1- 12 Wireless Base Station Application.....	1-11
Figure 1- 13 As a Full Channel Bank.....	1-12
Figure 1- 14 SNMP Connection	1-12
Figure 2- 1 Loop-V 4200 Front Panel	2-2
Figure 2- 2 Loop-V 4200 Rear Panel.....	2-2
Figure 3- 1 Bantam Jack Block Diagram	3-8
Figure 3- 2 SNMP Connection.....	3-10
Figure 4- 1 Loop-V 4200 series Front Panel.....	4-1
Figure 4- 2 Menu Tree	4-1
Figure 5- 1 Software Download Operation Setup - separate PC.....	5-9
Figure 5- 2 Software Download Operation Setup - single PC	5-10

EMC/EMI:

Compliance with : EN 55022 Class A, CISPR22 Class A

Compliance with : EN 50082, 50081

Compliance with : FCC 15

Safety Requirements

Compliance with : EN 60950, UL1950, CAN/CSA 22.2 NO. 950

Telecom

Compliance with : FCC68, CS-03, CE168X, BABT

FCC Requirements, Part 68

This equipment complies with Part 68 of the FCC rules. On the bottom cover of this equipment is a label that contains, among other information, the FCC registration number and ringer equivalence number (REN) for this equipment. If requested, this information must be provided to the telephone company.

Loop-V MuxMaster registration number and REN is as follows:

FCC 68 Registration Number: **IZITAI-27599-DE-N**

REN: **0.0B**

FACILITY INTERFACE CODE FOR DIGITAL SERVICES

CODE	DESCRIPTION
04DU9-BN	1.544 Mbps Superframe Format (SF) without line power.
04DU9-DN	1.544 Mbps SF and B8ZS without line power.
04DU9-1KN	1.544 Mbps ANSI ESF without line power.
04DU9-1SN	1.544 Mbps ANSI ESF and B8ZS without line power.

SERVICE ORDER CODES FOR DIGITAL SERVICES

CODE	DESCRIPTION
6.0N	Does not provide billing and encoded analog protection. Uses either an integrated or external CSU. Affidavit to telco is required.

Loop-V MuxMaster connects to the network using a RJ48C connector.

If this equipment cause harm to telephone network, the telephone company will notify you in advance that temporary discontinuance of service may be required. If advance notice isn't practical, the telephone company will notify the customer as soon as possible. Also, you will be advised of your right to file a compliant with the FCC if you believe it is necessary.

The telephone company may make changes in it's facilities, equipment, operations, or procedures that could affect the operation of the equipment. If this happens, the telephone company will provide advance notice in order for you to make the necessary modifications in order to maintain uninterrupted service.

Normally, this equipment will be used in conjunction with FCC registered equipment that limits the Encoded Analog Content and provides the required Billing Protection. If the connected equipment is not of this type, an affidavit must be supplied to the telephone company where the network connection is to be made. The affidavit is to be notarized, and is to be filed at least ten days before the initial connection.

If trouble is experienced with this equipment, please contact Loop Telecommunication America Service Facility for repair and warranty information. If the trouble is causing harm to the telephone network, the telephone company may request you remove the equipment from the network until the problem is resolved. All repairs should be handled by authorized Loop Telecommunication Service Personnel. Service can be facilitated through our office at:

Loop Telecommunication International
8 Carrick Road
Palm Beach Gardens, FL 33418
U.S.A.
(Tel) 561-627-7947
(Fax) 561-627-6615
(e-mail) <JIMBER/0007576940@MCIMAIL.COM>

This equipment cannot be used on telephone company-provided coin service. Connection to Party Line Service is subject to state tariffs.

FCC Requirements, Part 15

This equipment has been tested and found to comply with the limits for a Class A digital device pursuant to Part 15 of the FCC Rules. These limits are designed to provide reasonable protection against harmful interference when the equipment is operated in a commercial environment. This equipment generates, uses, and can radiate radio frequency energy, and if not installed and used in accordance with the instruction manual, may cause harmful interference to radio communications. Operation of this equipment in a residential area is likely to cause harmful interference, in which case the user will be required to correct the interference at the user's own expense.

Safety Requirements

IMPORTANT SAFETY INSTRUCTIONS

When using your equipment, basic safety precautions should always be followed to reduce the risk of fire, electric shock and injury to persons, including the following:

1. Use caution when installing or modifying telephone lines.
2. Never install telephone jacks in wet locations unless the jack is specifically designed for wet locations.
3. This equipment must be connected to an earth socket-outlet, which has a permanent connection to earth.

Save these instructions

National Electrical Code Requirements

The Loop-V MuxMaster – CSU/DSU, E1/T1 Converter & DACS is ITS Testing Laboratories certified to be in compliance with the Underwriters Laboratories (UL) 1950 Telephone Equipment Standard. The ETL control number is 75425.

DOC CS-03 Requirements

NOTICE: The Canadian Industry Canada label identifies certified equipment. This certification means that the equipment meets certain telecommunications network protective, operational and safety requirements. The Department does not guarantee the equipment will operate to the user's satisfaction.

Before installing this equipment, user should ensure that it is permissible to be connected to the facilities of the local telecommunications company. The equipment must also be installed using an acceptable method of connection. In some cases, the company's inside wiring associated with a single line individual service may be extended by means of a certified connector assembly (telephone extension cord). The customer should be aware that compliance with the above conditions may not prevent degradation of service in some situations.

Repairs to certified equipment should be made by an authorized Canadian maintenance facility designated by the supplier. Any repairs or alternations made by the user to this equipment, or equipment malfunctions, may give the telecommunications company cause to request the user to disconnect the equipment.

User should ensure for their own protection that the electrical ground connections of the power utility, telephone lines and internal metallic water pipe system, if present, are connected together. This precaution may be particularly important in rural areas.

Caution: User should not attempt to make such connections themselves, but should contact the appropriate electric inspection authority, or electrician, as appropriate.

The Load Number (LN) assigned to each terminal device denotes the percentage of the total load to be connected to a telephone loop which is used by the device, to prevent overloading. The termination on a loop may consist of any combination of devices subject only to the requirement that the total of the Load Number of all the devices does not exceed 100.

1. PRODUCT DESCRIPTION

1.1 Overview

The Loop-V 4200-9 is a versatile 9-port device. Depending on the plug-in cards selected, this unit can be configured (a) as a CSU/DSU with drop and insert and voice capabilities, (b) as a 4 E1 to 5 T1 converter or fractions of them, (c) as a digital cross-connect system (DACS), (d) as sets of ICSU combined in one box, and (e) as a channel bank. As a CSU/DSU, data from the V.35 or X.21 port can occupy any fraction of an E1 or T1 port. As an E1 to T1 converter, A to μ law and signaling conversions are correctly handled. For both E1 and T1 ports, continuous error checking, performance polling, and in-service diagnostics are provided. In any of the above combinations, full time slot interchange (TSI) among the ports are possible, making the Loop-V 4200-9 a small DACS (digital access cross-connect system). The ports can further be used in pairs as ICSUs (intelligent CSU) at lower cost and smaller space than individual ICSUs. Lastly, the Loop-V 4200 can be configured as a channel bank.

The Loop-V 4200-9 supports local control and diagnostics by using a 2-line by 40-character LCD display and keypads on the front panel, or by using a VT-100 terminal connected to the console port. The Loop-V 4200-9 also supports Ethernet, Telnet, and SNMP, so it can be controlled and diagnosed from remote locations. The Loop-V 4200-9 also supports inband Management, where management data is carried the same way as user data, traversing national networks.

In addition to the LCD display, 12 multicolor LEDs provide status indication for power, test condition, alarm, and each of the 9 ports. Internal firmware is stored in flash memory so that future software upgrades can be downloaded.

1.2 Physical Description

Loop-V 4200 MuxMaster is a compact box that can be either rack mounted taking up 1U of rack height or placed on desk top. Depending on the power plug-in card used, power can be either AC, DC, or dual DC module with dual DC feed.

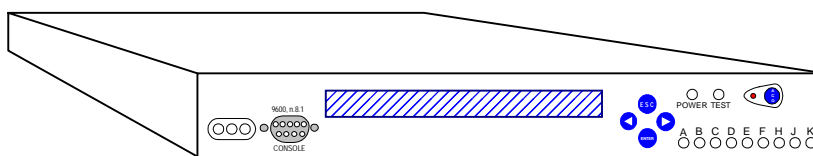

Figure 1- 1 Pictorial of Loop-V 4200 MuxMaster Series Products

1.3 Applications

Because of the variety of plug-in cards available, the applications for Loop-V 4200 MuxMaster are numerous. Only a few representative ones will be illustrated here. To the extent ports are available, combinations of illustrated applications are possible.

Important Note on Clock Source: Since the entire system operates on a single clock source, one of the input signal can serve as the master clock source. Each of the remaining input is presumed to synchronize to this master clock source. To the extent that the clock of any incoming line can drift with respect to the system clock, slips, or controlled slips, may occur.

1.3.1 As an ICSU

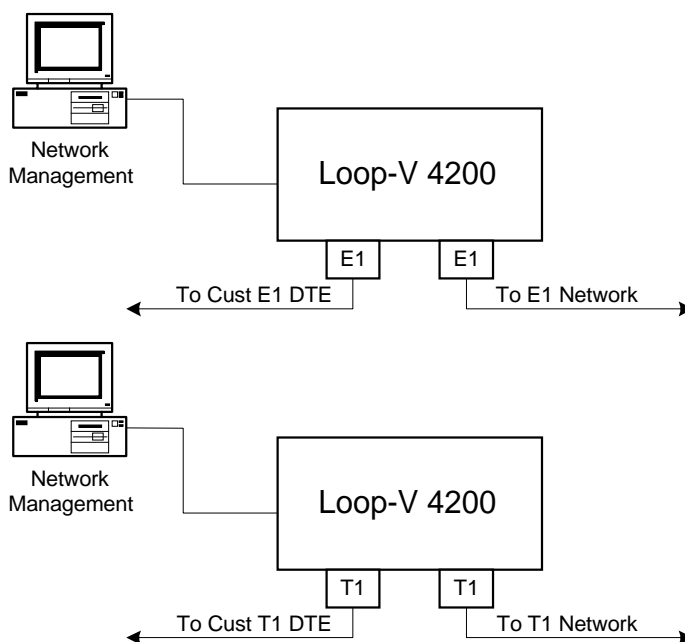

Figure 1- 2 As an ICSU

In this application, two slots are used in combination to provide the intelligent channel service unit (ICSU) function. This is used to terminate E1 or T1 lines at the customer site. Performance monitoring and maintenance functions, such as local and remote loop backs, are available. By using 4 slot-pairs, 4 independent ICSUs can be realized (see note on Clock Source above).

1.3.2 As a one-to-one E1 to T1 Converter

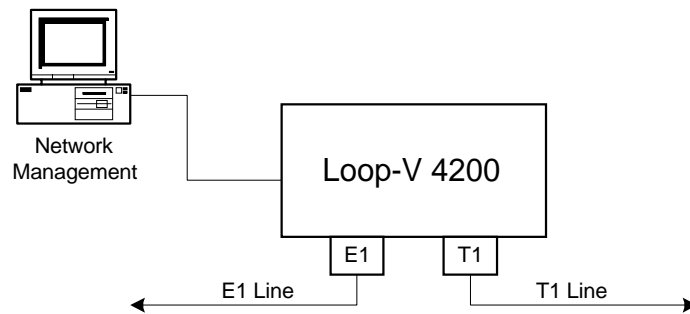

Figure 1- 3 As a one-to-one E1/T1 Converter

In this application, two slots are used in combination to provide one-to-one E1 to T1 conversion function. Because of the lower bit rate of the T1 line, only 24 time slots of the E1 line can be utilized in this interconnection. User can assign any 24 of E1 time slots to any of the 24 T1 time-slots. For digitized voice, A-law to μ -law conversion will be performed. For CAS (channel associated signaling), the signaling bits will be placed in their proper places in the respective E1 and T1 formats. Performance monitoring and maintenance functions, such as local and remote loop backs, are available. By using 4 slot-pairs, 4 independent one-to-one E1 to T1 converters can be realized (see note on Clock Source above).

In a related application, time slots left over on the E1 side can be filled with data from a DTE plug-in card.

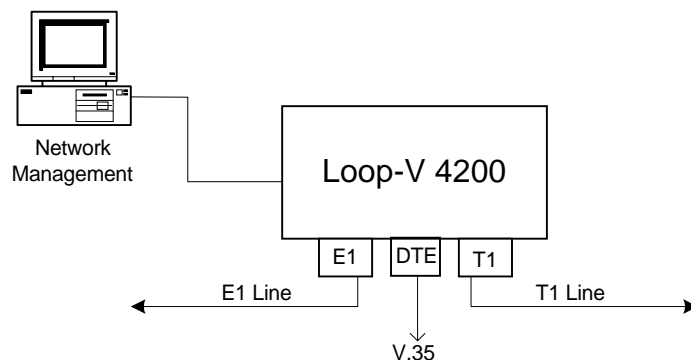

Figure 1- 4 As a One-to-One E1/T1 Converter plus Data

1.3.3 As a One-to-Two E1 to T1 Converter

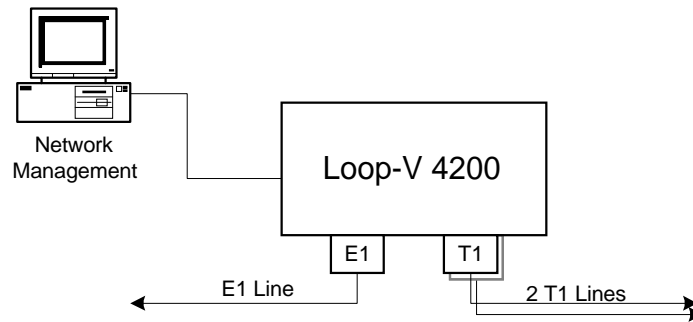

Figure 1- 5 As a One-to-Two E1/T1 Converter

In this application, three slots are used in combination to provide one-to-two E1 to T1 conversion function. Because of the combined bit rate of two T1 lines is higher than one E1, all 31 time slots of the E1 line can be assigned. User can assign each of 31 E1 time slots to any of the 48 time-slots available in 2 T1s, with time slots left over in the T1s. For digitized voice, A-law to μ -law conversion will be performed. For CAS (channel associated signaling), only 30 time slots can be assigned with the signaling bits placed in their proper places in the respective E1 and T1 formats. Performance monitoring and maintenance functions, such as local and remote loop backs, are available. By using all eight available slots, 2 independent one-to-two E1 to T1 converters can be realized along with a one-to-one converter (see Clock Source note above).

In a related application, similar to Figure 1-4, time slots left over in one or both T1s can be filled with data from a DTE plug-in card.

1.3.4 As a Four-to-Five E1 to T1 Converter

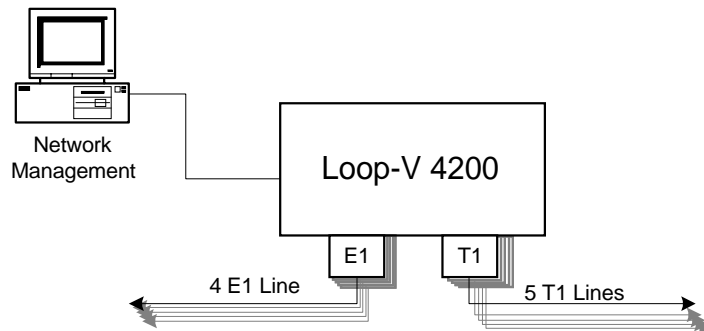

Figure 1- 6 As a Four-to-Five E1/T1 Converter

In this application, an optional 9-slot version of the Loop-V 4200 MuxMaster is used to provide four-to-five E1 to T1 conversion function. Each E1 is assumed to use only 30 time slots with time slot 16 reserved for signaling. Because the total time slots for four E1 lines and for five T1 lines are both 120, both bundles can be fully occupied for traffic. User can assign any of 30 time slots from any of four E1 lines to any of the 24 time-slots of any of five T1s. For digitized voice, A-law to μ -law conversion will be performed. For CAS (channel associated signaling), the signaling bits will be transferred to their proper places in the respective E1 and T1 formats. Performance monitoring and maintenance functions, such as local and remote loop backs, are available. This application provides users with utilization of both E1 and T1 lines.

1.3.5 As an E1 or T1 DACS

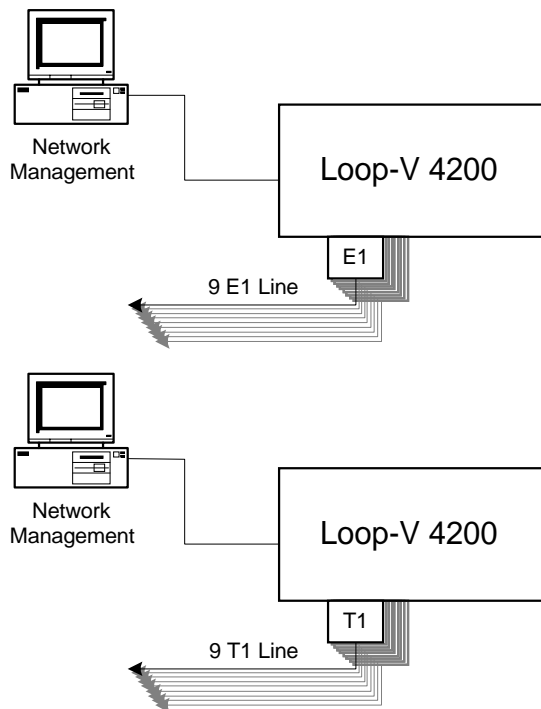

Figure 1- 7 As a 8-Line E1 or T1 DACS

In this application, the Loop-V 4200 MuxMaster is used as a digital access cross-connect system (DACS). Up to 9 slots can be equipped with either E1 or T1 plug-in cards, or even mixed, wherein any time slot of any port can be cross-connected to any time slot of any port, including itself. Performance monitoring and maintenance functions, such as local and remote loop backs, are available.

1.3.6 As a Network Access Device for Data

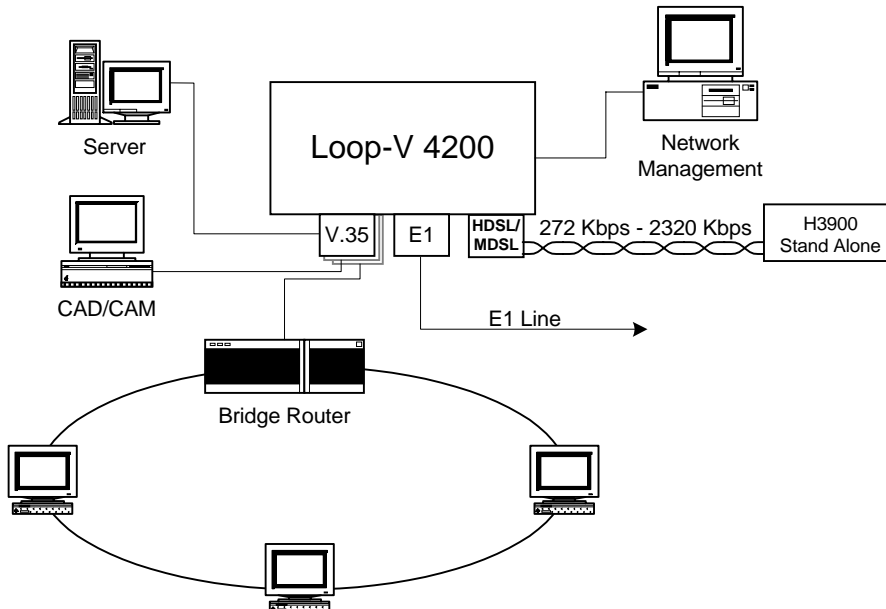

Figure 1- 8 As a Data Access Device for Digital Networks

In this application example, the Loop-V 4200 MuxMaster is used as an access device to the digital network. The various data applications can be LAN or WAN, data servers and hosts, and CAD/CAM. This allows users to integrate different applications into a single communication link and utilizing only a part of the available bandwidth. Furthermore, expansion of the bandwidth utilization is readily accomplished. As usual, performance monitoring and maintenance functions, such as local and remote loop backs, are available.

1.3.7 As an ATM Frame Relay Transport Device

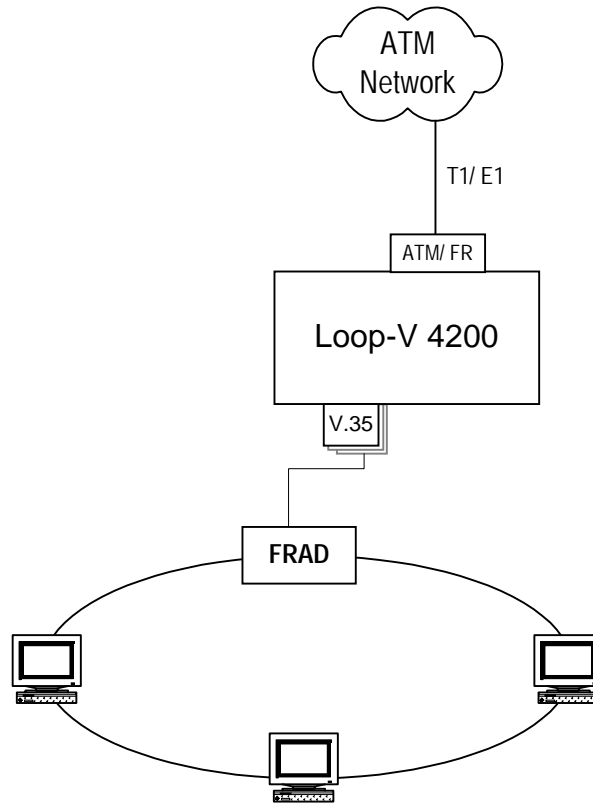

Figure 1- 9 As an ATM Frame Relay Transport Device

1.3.8 As a Router Transport Device

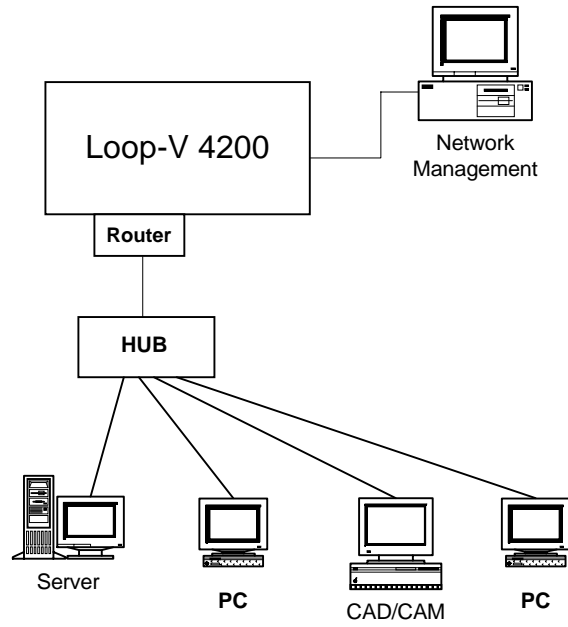

Figure 1- 10 As a Router Transport Device

1.3.9 As a Drop-and-Insert Unit for Voice and Data

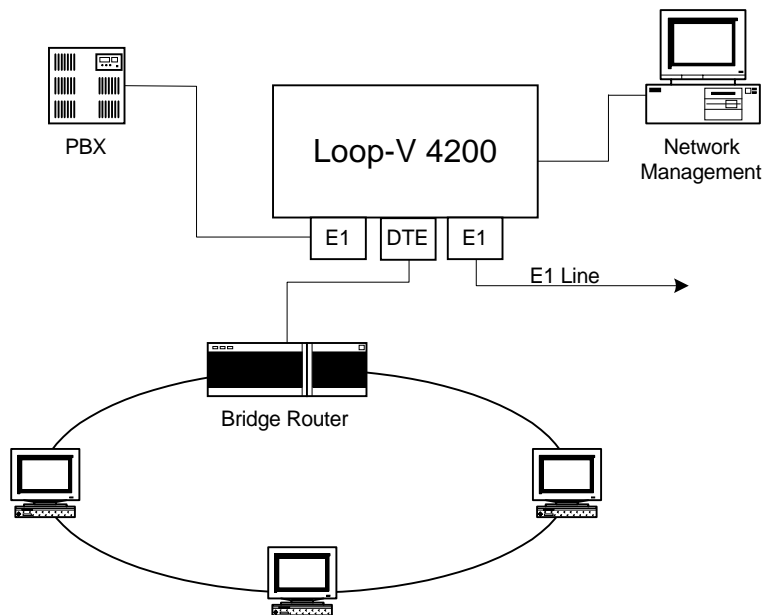

Figure 1- 11 As a Drop-and-Insert with Voice and Data Access

When only a partial of the available time slots of a digital access line is used, the Loop-V 4200 can be used as a drop-and-insert device to fill the unused capacity with data or voice by use of data or voice plug-in cards.

1.3.10 As a Wireless Base Station Signal Multiplexer

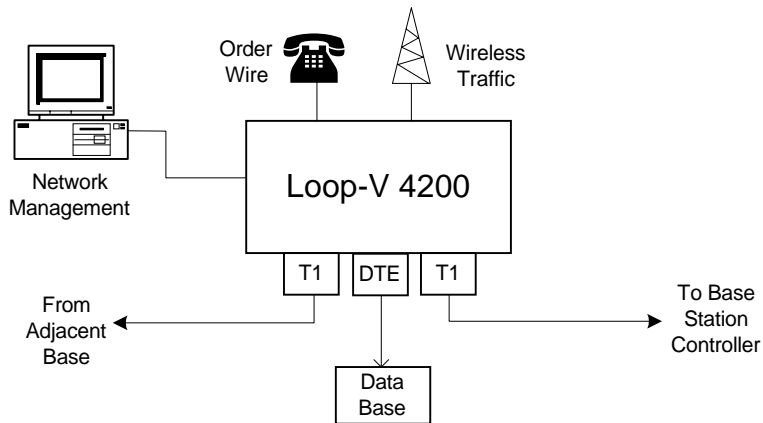

Figure 1- 12 Wireless Base Station Application

In a wireless base station, several digital signals plus a telephone for order wire, needs to be combined. The digital signals include the digitized wireless telephone traffic, the fraud detection data base traffic, and traffic from adjacent base stations.

1.3.11 As a Full Channel Bank

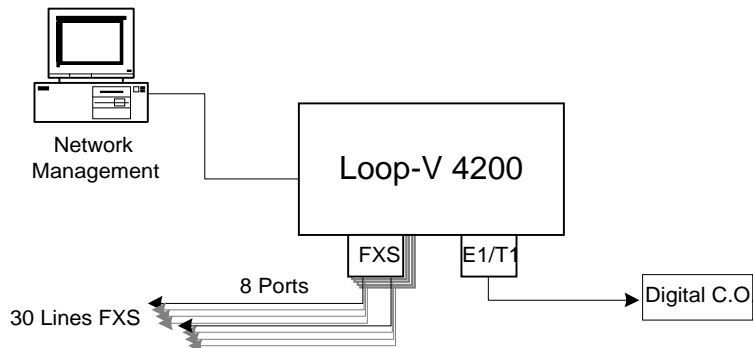

Figure 1- 13 As a Full Channel Bank

Equipped with FXS or FXO plug-in cards, the Loop-V 4200 can be used as a full or fractional channel bank.

1.3.12 As a Combined Network Access and Management Channel Access Device

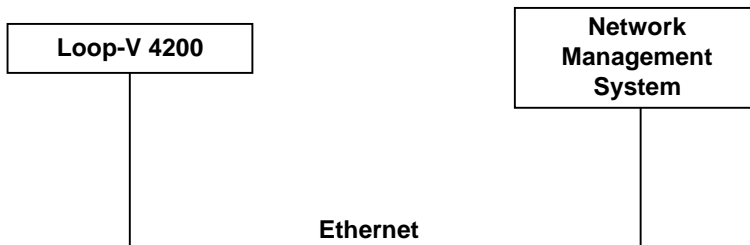

Figure 1- 14 SNMP Connection

1.4 Specifications

Time Slot Interchange

Less than 400 μ s delay

One active map, one user stored map

Voice Channel Conversion

A-law to μ -law G.711

CAS Signaling Transparent, (A=0 from E1 becomes A=0 to T1, etc.)

Electrical Power

Field changeable 30W 24Vdc or 30W 48Vdc power supply module

DC : 24Vdc, 3A Max.

48Vdc, 1.6A Max.

AC : 90 to 240 Vac, 50/60 Hz, 2A Max.

Physical

Dimensions 43 x 4.4 x 33 cm, 17" x 1.75" x 13" (WxHxD)

Temperature Range 0 – 50 °C

Humidity 0 – 95% RH (non-condensing)

Mounting Desk-top stackable, 19/23 inch rack mountable

Weight 7.7 lb., (3.5Kg) without plug-in cards

Performance Monitor

Performance Store The last 24 hours performance in 15-minute intervals

Monitor Registers Line, user

Performance Reports Date & Time, Errored Second, Degraded Minutes, Unavailable Second, Bursty Errored Second, Severe Errored Second, Controlled Slip Second, and Loss of Frame Count

Alarm History Date & Time, Alarm Type (i.e. Master Clock Loss, RAI, AIS, LOS, BPV, ES, CS)

Threshold Bipolar Violation, Error Second, Unavailable Second, Controlled Slip Second

Network Management

Connector DB9 at front panel

Electrical RS232 interface

Protocol Menu driven VT-100 terminal

Ethernet Port (optional)

Connector RJ45 in rear

Protocol Telnet and Embedded SNMP

Front Panel

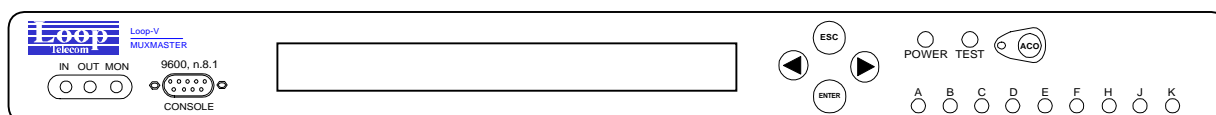

Keypads 5 keys, ACO (alarm cut-off), left and right arrows, ESC, and ENTER

LCD 2 lines by 40 characters LCD display

LED 12 - one for each of 9 plug-in slots, power, test, and alarm

Bantam Jacks Network IN, OUT, and Monitor

Rear Panel

2. INSTALLATION

2.1 Site Selection

The following are guidelines for site selection. These guidelines must be followed to ensure proper installation.

If it is to be rack mounted, location of the Rack Cage should be part of the central office equipment layout design. Considerations should be given to entrance cable routing and -48 Vdc power cable routing if needed. The installation site should have the appropriate power feed, 110 or 220 Vac or -48 Vdc power. If dual feed is desired, dual independent -48 Vdc feed would be needed.

Similar considerations should be given for mounting on desktop. The unit is stackable, using available protective rubber feet for each unit.

The following are the maximum suggested cable lengths:

- | | | |
|-----------|---------------------------|----------|
| 1. V.35 | 70 m | 200 feet |
| 2. RS449 | 70 m | 200 feet |
| 3. RS232 | 15 m | 50 feet |
| 4. EIA530 | 70 m | 200 feet |
| 5. X.21 | 70 m | 200 feet |
| 6. MDSL | (see the following table) | |

The installation site should provide space for adequate ventilation and cable routing. Reserve at least 5 inches at the rear of the unit for cables and air flow.

The site should provide a stable environment. The operating area should be clean and free from extremes of temperature, humidity, shock, and vibration.

Relative humidity should stay between 0 and 95%. Do not operate the unit at an altitude greater than 4000m (13,000 feet).

The length of any lines, such as T1 or E1, must not exceed 1520m (5000 feet).

2.2 Mechanical and Electrical Installation

2.2.1 Mechanical Installation

The Loop-V 4200 MuxMaster can be installed as a desk top unit or mounted in a 19 or 23-inch rack. Since all plug-in cards are hot-swappable, the unit can be powered up and all cards (except the power card and LAN card) can be plugged in or removed at any time without affecting the operation of the rest of the unit.

The front panel is shown in Figure 2-1, and the rear panel is shown in Figure 2-2.

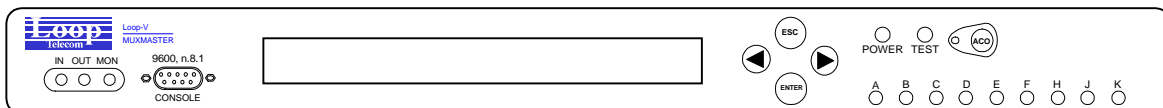

Figure 2- 1 Loop-V 4200 Front Panel

IMPORTANT NOTE: Make sure each plug-in card is fully seated and lock-in screws tightened. Permanent damage may result from a card left in the partially seated position.

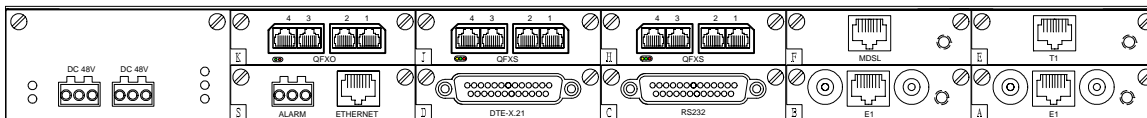

Figure 2- 2 Loop-V 4200 Rear Panel

Chapter 2 Installation

2.2.2 Electrical Installation

Either AC power or DC power will be used, depending on the model ordered. Power connection is at the rear panel. For the AC model, a power cord is supplied. For the DC model, -48 Vdc power is via a 3-pin terminal block. Table lists pin definition.

Table 2- 1 Power Connector

Pin Number	Signal	Description
1	-V	-DC 24 to 48 Volts
2	+V	+DC Return
3	Chassis Ground	

If dual module dual feed power supply is to be installed, wire independent power feeds to the power supply card. With dual feed, if any one power source fails, or if any one power module fails, the remaining functions of the unit will continue. If only one power feed is used, the advantage of dual power module is still available. One LED for each power module indicates the status of that power module. When one power module has failed, a scheduled replacement of the entire module is necessary.

The Loop-V 4200 MuxMaster is designed to allow for "hot plug-in". This means that interface cards can be inserted and removed with the main chassis powered up. After each change of the plug-in cards, the previous configuration of the port will be used if the replaced card is of the same type. Else the factory default configuration for that card type will be used. User must change the configuration from the default if a different card type is inserted.

Chassis Grounding

The chassis is grounded when rack mounted. However, for stand alone units or extra grounding protection for rack mounted units, a dedicated chassis ground screw and lock washer is provided. The chassis ground screw is located on the side of the unit close to the power supply.

When attaching a ground wire to the chassis ground screw, please follow these instructions.

- Use copper grounding conductors of the same AWG, or thicker, than those used on the power connections
- Conductors should not be of dissimilar metals.
- The bare conductors should be coated with anti-oxidant before crimp connections are made.
- Unplated connection surfaces, connectors, braided strap and bus bars must be bought to a bright finish and coated with anti-oxidant before connections are made.
- Listed connectors and fastening hardware must be used.

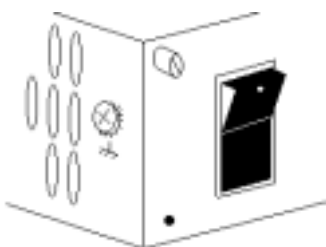

The chassis ground screw.

Chapter 2 Installation

2.3 Terminal Connection

For connection to a VT100 type terminal for maintenance and administration, a console port with a DB9 connector is located on the front panel. For remote terminal connection through a modem, an adapter cable from DB9 to DB25 must be used. If ordered with Ethernet card, that card should be plugged into the designated slot in the rear. The RJ45 connector on the panel of that card is for an Ethernet connection. The console port is configured as a DCE device. It is designed to match the DB9 PC COM PORT of most lap-top computers. Pin definitions are listed in Table 2-3.

Table 2- 2 Console Port

Pin Number	Signal	Source
1	Data Carrier Detect	To DTE
2	Receive Data	To DTE
3	Transmit Data	From DTE
4	Unassigned	
5	Signal Ground	
6	Data Set Ready	To DTE
7	Unassigned	
8	Clear to send	To DTE
9	Unassigned	

Ethernet port can be connected via Ethernet 10-Base-T interface. Pin definition is listed in Table 2-3.

Table 2- 3 Ethernet Port

Pin Number	Signal	Description
1	TPTX+	TP Driver Output
2	TPTX-	
3	TPRX+	TP Receive Input
6	TPRX-	
7	Chassis GND	
8	Chassis GND	

Table 2- 4 Alarm Relay Connector

Pin Number	Signal	Description
1	Alarm Fuse	Normal Close
2	Alarm Fuse	Common
3	Alarm Fuse	Normal Open

2.4 Configuration Setting

2.4.1 Hardware Configuration Setting

Other than exceptions noted below, most configurations are software programmable. Users should not need to remove any plug-in cards for modifications other than mentioned below.

2.4.2 Software Configuration Setting

The system configuration is stored within the main chassis. When a plug-in card is inserted, the configuration for that card will be the factory default until changed by the user. There are three system configurations:

Factory default - There is a factory default for each type of plug-in card

Current working

User-stored

Factory default configurations are not changeable. Each Loop-V 4200 series is shipped with all three configurations set to the factory default configuration.

The current working configuration can be changed at any time. The system stores the current working configuration into nonvolatile memory. When the system is turned off and then turned back on again, the previous working configuration is retrieved as the current working configuration.

The current working configuration may also be saved into nonvolatile memory as a user-stored configuration. The user-stored configuration may be retrieved at any time. Retrieving the user-stored configuration overwrites the current working configuration. The user can view the stored unit configuration using the terminal command "R" before retrieving it.

The following steps can be used to restore the controller card to the factory default configuration:

1. Press the **ESC** and **ENTER** key during power-up, while "SELF TEST" is displayed on the front panel LCD.
2. Verify that LOAD DEFAULT CONFIGURATION is being displayed on the front panel to indicate that the operation was successful.

Each of the plug-in cards can be returned to factory default setting through commands from the controller card.

2.4.3 Replacement of Plug-in Card

When a plug-in card is removed and replaced with a card of a different type, default configuration is assigned to the new card. The user must set the configuration for each change of card type. If the same type card is inserted, depending on card type, then the following happens:

- For E1, T1, and DTE plug-in cards, the previous configuration is automatically downloaded.
- For Router plug-in card, the factory default configuration is assigned to the new card.
- For E1/ T1 ATM Frame Relay plug-in card, (a) The port configuration for E1 or T1 is automatically downloaded, (b) The Frame Relay management setup is factory default configuration.

Chapter 2 Installation

Table 2- 5 Default Software Configuration

Console Port	Default
Baud Rate	9600
Data Length	8
Stop Bit	1
Parity Bit	NONE
XON-XOFF	OFF
TSI_FUNC	1:1 (Bidirection)

Active Map	Default
MAP1	all idle
Master Clock	Internal
2nd Clock	Internal
Password lock	Disable

Alarm Threshold	Default
Alarm Enable	Disable
BPV, Line	10E- 5
ES, Line	1
UAS, Line	1
CS, Line	1

Miscellaneous Items	Default
Password	LOOP
Device Name	LOOP V4200-9

3. OPERATION

This chapter describes the Loop-V 4200 MuxMaster configuration options and operational functions. User should refer to CHAPTER 5: FRONT PANEL OPERATION, CHAPTER 6: TERMINAL OPERATION for detailed operational procedures for each interface card type.

3.1 Quick Start for Loop-V 4200 E1/T1 Converter/TSI

After installation, the user may want to familiarize with the equipment immediately. The following abbreviated instructions will give the user a quick start.

3.2 Power On

Turn power on by attaching power cable at the rear of the unit. On the LCD, unit will first display SELF TEST followed by the main menu.

Return to Default Setting

The unit is shipped with factory default setting.

To restore factory setting in the future, immediately after power on, and during the display of "SELF TEST" on the LCD, press and hold both **ESC** and **ENTER** keys until the display of "LOAD DEFAULT CONFIGURATION" on the LCD.

3.3 Self-Test

At system power up, a complete self-test routine is run to check all I/O ports, read/write memory, and data paths to validate system integrity. During the system self test, "SELF TEST" message is shown on the upper line of the LCD display. The software release version and date code is shown on the lower line of the LCD display. If an error is found, FAIL is shown in the upper right corner of the LCD display and a dedicated error message is shown on the lower line. Users may press **ESC**, left arrow (<), right arrow (>), and **ENTER** key in this order to read a specific error code. If no error is found, the LCD display will show "PASS" in the upper right corner of the LCD display followed by a Main Menu as FIGURE 5.2. Various system diagnostic methodology can be found in the following paragraphs.

3.4 Using Front Panel

To use the front panel to configure the unit, use the four keys to the right of the LCD. The menu is tree structured, with the main menu at the root of the tree. The **ESC** key brings the user towards to root. The **ENTER** key is used (a) to descend to branches of the menu, or (b) to confirm a selection. The left and right arrow keys are used to move the selection left or right.

3.5 Review of Default Settings

All the default settings can be reviewed or changed. This is done by selecting the menu item. Either a sub-menu is shown or the selected setting is indicated with an asterisk.

3.6 Line Interface Selection

After power up, the MAIN menu is shown with the PORTS highlighted. Press **ENTER** to go to PORTS sub-menu, which allows selection of one of 9 slots where an interface card may be inserted. The type of card inserted in that slot is shown and the sub-menu for that card type is indicated. If a slot is vacant, it will not be shown.

3.7 Line

From the PORTS menu, depending on the card type inserted, further sub-menus can be selected. To review or change line settings for that card, use arrow keys to highlight LINE. Then press **ENTER**. Use arrow keys to select the parameter. Then press **ENTER**.

Chapter 3 Operation

For each sub-menu, the default line parameters are shown. The actual settings are shown for each parameter, which can be changed by arrow keys.

To change the settings, use **ENTER** key to select the parameter, use arrow key to select the new setting, and then press **ENTER** again. If **ESC** is pressed before **ENTER**, the setting will not be changed.

3.8 Map Setup

The next item under MAIN is TSIMAP, which determines the time slot interchange assignments (TSI). To review or change MAP settings, use arrow keys to highlight MAP. Then press **ENTER**. The current active map is indicated.

To review or change MAP settings, use arrow keys to move cursor to MAP. Then press **ENTER**. The current active map is indicated. Using the LCD display, the MAP settings can only be reviewed. Changing the MAP settings require either a terminal or a connection through the Ethernet to a management system.

Note that if a slot is equipped with a data card or voice card, "time slot" will not be relevant. Instead, the number of time slots to be assigned to the data stream, which turn determines the total data rate, can be set. Under the LINE menu, user can select either Nx56 or Nx64 data rate. Then, depending on how many time-slots are assigned on a E1 or T1 line for that data, the final data rate will be determined.

3.9 Using Terminal

To use the RS232 interface to configure the unit, connect a VT100 terminal to the DB9 jack on the front panel using the supplied adapter cable and a null modem. The VT100 terminal can be a PC running a VT100 emulator software. The unit is configured as a DTE. Thus a null modem is needed for direct connection to a VT100.

Upon connection, press **ENTER** and **ESC** alternately to bring the main menu into view.

Press O (Log On) to see the full menu.

Press S (System Setup) to review or change the configuration.

Unit Selection

The first CONTROLLER screen on the terminal has a line on Card Status. For each of the 9 interfaces, an I means that a card is in place, an O means that the slot is vacant. If an alarm exist for the card, ALM is displayed. Press U followed by the slot number to choose a card interface.

3.10 System Operation

3.10.1 Date

The main chassis is equipped with a RTC (Real Time Clock). User can change the current date and time as necessary. The RTC is activated by the manufacturer before shipping. The RTC battery has a 10 years power-off life cycle.

3.10.2 Master Clock

Loop-V 4200 has a system clock PLL (Phase Lock Loop), which may be phase locked to any one of the 9 ports that has clock input, or internal clock.

The default clock configuration are as follows: (a) master clock, (d) current clock, (c) clock recover. When the master clock source is lost, the system will automatically switch to second clock source.

This is used to provide an alternative clock source when the primary clock source is lost, the current active clock source is shown by the LCD "MCLK" command and terminal "S" command.

NOTE: if the second clock source is lost as well, Loop-V 4200 will automatically switch to the internal clock source.

If clock recover mode is manual, Loop-V 4200 will not return to the master clock source when the master clock source returns. In order to switch back to the master clock source, the clock must be reselected as the master clock source via the front panel "MCLK" command or the terminal "S" command.

Chapter 3 Operation

If clock recover mode is automatic, Loop-V 4200 returns to the master clock source one minute after the master clock is recovered. The current active clock source is automatically changed to master clock.

3.10.3 Console Port

The console port allows the user either to use a local VT-100 terminal or use a remote VT-100 terminal via modem for system configuration, diagnostics, polling status reports, etc. An adapter cable from DB9P to DB25P is required for modem operation. The console port baud, data bit length, stop bit length, parity bit length, XON-XOFF flow control, and interface type are defaulted, as shown below.

Table 3- 1 Console Port Setting

Item	Fixed Setting
Baud	9600
Data Length	8
Stop Bit	1
Parity	NONE
XON-XOFF	OFF
Interface	DCE

3.10.4 Menu Lock

The LCD front panel and terminal are used to read alarms, system configurations, and system status. They also can be used to change system configurations and clear the alarm queue, etc.. By enabling the menu-lock, only read operations are allowed. Modifications to the current status are not allowed. Users may not change system configurations or clear performance data. Menu Lock at the LCD and Password configuration at the terminal are coordinated.

Password and menu-lock options are disabled by default.

- The default password is LOOP.

3.10.5 Logon, Logoff, and Password

Logoff prevents system configuration changes at the terminal, while logon allows system configuration changes. The password feature is used to augment lock control against unauthorized terminal users from changing system parameters, either from the terminal or from the LCD panel. With password enabled, logon requires entering the correct password. If password is disabled, no password is required to logon.

- The default option of the password is disabled.
- The default password is LOOP.

3.11 Configuration

User can save the current configurations onto a non-volatile memory. This allows user to retrieve the last stored configuration. Except for the time slot interchange configuration described below, which is part of the main chassis, all other configurations refer to the plug-in cards, which are operative only when one or more cards of those types are installed.

3.12 Time Slot Interchange (Digital Access Cross-Connect)

An important function of the Loop-V 4200 is time slot interchange (TSI), also known as digital access cross-connect (DACS), where each DSO time slot of any line can be assigned to any DSO time slot of any line including itself. The assignment table is called a map. A map contains the DSO time slot assignments of all time slots for all lines. An idle code is transmitted on all unused time slots. The default DSO time slot assignment of all ports is idle channel. When a time slot is assigned to itself, for example A01 to A01, loopback of that time slot towards the line results.

Chapter 3 Operation

In the case of a data type plug-in card, the data will be assigned to as many DS0 time slots as the data rate requires. These DS0 time slots must be assigned to the same port, though not necessarily contiguous DS0 time slots of that port.

NOTE: For E1 network interface with HDB3 coding or T1 network interface with B8ZS coding all remote DTE ports with 56 Kbps, all time slots are available for any DS0 assignment, data or voice.

However, for either network interface with AMI coding, user should assign only alternate odd or even DS0 time slots for 64 Kbps data. This is to guarantee one's density requirement.

In addition to setting time slot assignments, the user must also select the signaling format used for each of the lines and indicate the channel type for each channel. Signaling format can be CAS (channel associated signaling) or CCIS (common channel interoffice signaling). In the case of CAS, the E1 format uses time slot 16 for that purpose, thus this time slot is not available for assignment. The channel type can be data or voice. In the case of voice, the coding scheme, A-law for E1 and μ -law for T1, will be converted as well. In addition, for CAS, T1 uses robbed bit signaling while E1 uses time slot 16. This will also be handled according to ITU rules.

NOTE: Because a time slot from a port with CAS must be assigned to a port also with CAS, user must first configure the plu-in card for CAS ON or OFF before setting time slot assignment. Also, if the user want to change a plug-in card CAS setting, all time slots assignments should be remove to avoid sync problems.

NOTE: To avoid certain data entry errors when assigning TSI time slots, the user should first set the affected time slots to idle. Then assign those time slots. Else, a warning of time slot assignment overwrite will appear.

Because of the complexity of the TSI Map, the front panel LCD operation would only allow for the display of the map. To set the TSI Map initially, a VT100 terminal, or a central control using TELNET must be used.

For E1 or T1 card plugged into a slot, each of the 31 or 24 available 64 Kbps time slots can be assigned to any 64 Kbps time slot of any port. For the FXS card plugged into a slot, each of the two FXS ports can be assigned to any 64 Kbps time slots of any other E1 or T1 port.

3.13 Alarms and Reports

3.13.1 Alarms

Except for the FXS card, for each other type of plug-in card, Loop-V 4200 series has many types of alarms as listed in Table 3-2. Also, Loop-V 4200 has alarm queue which record the latest 40 alarms with time stamp. Loop-V 4200 also has alarm history and alarm status registers which is used to track the alarm count. Each alarm can be individually enabled or disabled. When disabled, no action is taken. When enabled, alarm counter increments on the occurrence of the specific type of alarm. When alarm occurs or the counter threshold exceeds, alarm is triggered.

All alarms are disabled by default.

Individual fault counts are updated every second. Bipolar Violation (BPV) counts are updated every second, but the BPV alarm is based on an average Bit Error Rate (BER) that is calculated over a 15-minute interval. Therefore, BPV alarm status is updated every 15 minutes after the average BER is calculated. If the average BPV rate exceeds the preset threshold i.e., from 10^{-9} up to 10^{-5} , an alarm can be declared (assuming BPV alarm is enabled). ES and UAS employ threshold-triggered alarms, but these alarms are declared as soon as the recorded account exceeds the preset threshold. The 15-minute integration interval does not apply to ES and UAS alarms. Alarm register states are reset every 15 minutes, but preserved in the Alarm History display.

Table 3- 2 Alarm Type Table

ALARM TYPE	ALARM DESCRIPTION	THRESHOLD
"RAI/YEL"	Yellow Alarm	no
"AIS"	Alarm Indication Signal	no
"LOS"	Loss of Signal	no
"LOF"	Loss of Frame	no
"BPV"	Bipolar Violation 10E- (5, 6, 7, 8, 9)	yes (default 5)
"ES"	Error Second (0 to 900)	yes (default 1)
"UAS"	Unavailable Second (0 to 900)	yes (default 1)
"CSS"	Control Slip Second (0 to 900)	yes (default 1)
DTE	DTE port, RTS loss of clock in TTM	

3.13.2 Report

For E1 and T1 type plug-in cards, Loop-V 4200 has three sets of performance registers. These are line, user, and far-end. The line performance register tracks the line receiver performance status. The user performance register tracks the line receiver as well, but user may clear at any time. The far-end performance register tracks the far-end Loop-V 4200 receiver status. The performance parameters are listed in Table 3-3 and 3-4. User performance register have two additional parameters. One is BPV register to count bipolar violation in both D4 and ESF modes. The other is ESF to track framing error and CRC error in ESF frame format mode only, or CSS (controlled slip second) for E1.

Each performance parameter has ninety six sets of registers to record 24 hours history in 15 minute interval.

Table 3- 3 Performance Parameter List - T1

Performance Parameter	Description	Definition (T1/D4)	Definition (ESF)
ES	Error Second	$BPV \geq 1$, $OOF \geq 1$, or $CS \geq 1$.	$CRC \geq 1$, $OOF \geq 1$, or $CS \geq 1$.
BES	Bursty Error Second	$1 < BPV < 1544$	$1 < CRC < 320$
SES	Severe Error Second	$BPV \geq 1544$, or $OOF \geq 1$	$CRC \geq 320$, or $OOF \geq 1$
CSS	Controlled Slip Second	frame slip ≥ 1	frame slip ≥ 1
OOF	Out of Frame	2 frame bit error in 6 consecutive frame bits	2 frame bit error in 6 consecutive frame bits
LOFC	Loss Of Frame Count	OOF for 2.5 0.5 sec	OOF for 2.5 0.5 sec
UAS	Unavailable Second	10 consecutive SES	10 consecutive SES
BPV	Bipolar Violation	Bipolar Error Count	Bipolar Error Count
ESF	CRC Error, or Out Of Frame	(not used, always 0)	CRC error or OOF

Chapter 3 Operation

Table 3- 4 Performance Parameter List - E1

Performance Parameter	Description	Definition 2-Frame/Multiframe	Definition 16-Frame/Multiframe
ES	Error Second	BPV \geq 1, OOF \geq 1, or CS \geq 1.	CRC \geq 1, OOF \geq 1, or CS \geq 1.
BES	Bursty Error Second	1 < BPV < 2048	1 < CRC < 805
SES	Severe Error Second	BPV \geq 2048, or OOF \geq 1	CRC \geq 805, or OOF \geq 1
CSS	Controlled Slip Second	Frame slip \geq 1	Frame slip \geq 1
OOF	Out of Frame	1 frame sync loss in 6 consecutive frame bits	1 frame sync loss in 6 consecutive frame bits
LOFC	Loss Of Frame Count	OOF for 2.5 \pm 0.5 sec	OOF for 2.5 \pm 0.5 sec
UAS	Unavailable Second	\geq 10 consecutive SES	\geq 10 consecutive SES
DM	Degraded Minute	BPV \geq 123	CRC \geq 47

Table 3-5 lists the types of reports available, performance parameters provided by each report, and the reset commands for each report.

Table 3- 5 Performance Report Options

Report Type [Menu Command]	Category	Report							
		ES	UAS	BES	SES	CSS	LOFC	BPV	ESF
Front Panel Reports	USER [Network]	Y	Y	Y	Y	Y	Y	Y	—
1-Hour Terminal Reports Menu Option [1]	USER [Network]	Y	Y	Y	Y	Y	Y	—	—
	LINE [Network]	N/C	N/C	N/C	N/C	N/C	N/C	—	—
	FAR-END	N/C	N/C	N/C	N/C	N/C	N/C	—	—
24-Hour Terminal Reports Menu Option [2]	USER [Network]	Y	Y	Y	Y	Y	Y	Y	Y
	LINE [Network]	N/C	N/C	N/C	N/C	N/C	N/C	N/C	N/C
	FAR-END	N/C	N/C	N/C	N/C	N/C	N/C	—	—
CRC Error Count Terminal Reports Menu Option [E]	USER [Network]	—	—	—	—	—	—	—	Y X
	LINE [Network]	—	—	—	—	—	—	—	N/C
	FAR-END	—	—	—	—	—	—	—	N/C

Y = Report available and can be cleared by front panel "RESET" or admin terminal command "Y".

X = Report available and can be cleared by front panel "RESET" or admin terminal command "X".

N/C = No clear. Report available, but counts cannot be cleared by the user.

— = Report not available.

3.14 Requesting Report

The performance report can be accessed from local terminal directly or from remote terminal via internet. In both T1/D4 and ESF frame format mode, the performance report can be accessed from local terminal directly or from remote terminal via internet.

Also, in ESF mode, performance report can be accessed via data link. User will choose either AT&T or ANSI T1.403 data link operation in DS1 network line interface configuration. AT&T TR 54016 should be referred to as how the performance report request message and response message are structured. ANSI T1.403 should be referred to how the one second performance report message structured.

Loop-V 4200 supports both AT&T TR 54016 and ANSI T1.403 performance report message.

For the E1 link, remote terminal access via modem or Ethernet could be used.

3.15 LED Operation

The front and back panel each has 10 LEDs, one for power and one each for each line. Table 3-6 lists each LED and its color and indications. Each plug-in has a back panel LED, which match the corresponding front panel LED, except as noted.

Table 3- 6 Front and Back Panel LED Table

LED	Color	Indication
POWER	Green Off	Powered on Normal Power off, or self-test failure
TEST	Amber Off	During controller initialization Complete controller initialization
ACO	Red Off	Alarm relay active Alarm relay inactive

3.16 Bantam Jack

Figure 3-1 shows the block diagram of the bantam jack. Only "to-line" jacks for port A are provided. Users are advised to use port A for the primary E1 or T1 line connection.

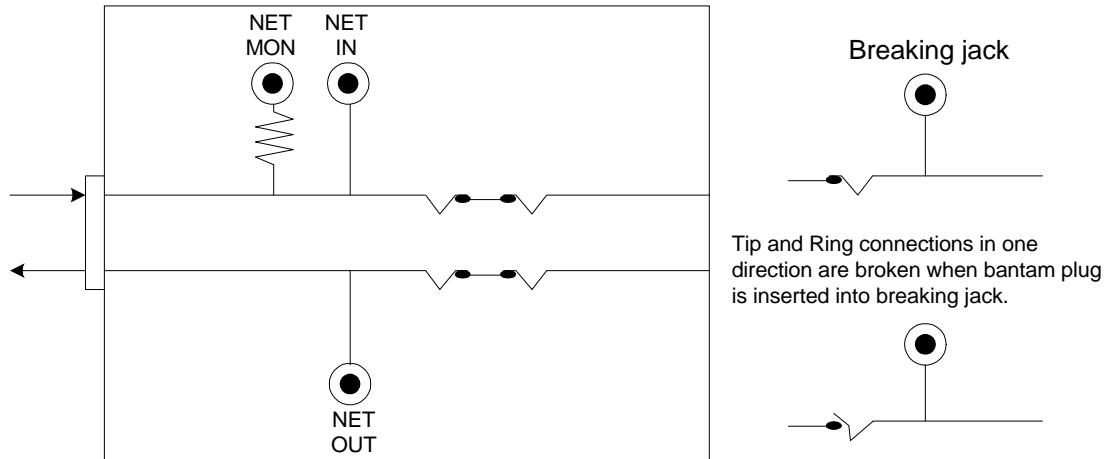

Figure 3- 1 Bantam Jack Block Diagram

3.17 Error Messages

Loop-V 4200 provides various error messages on LCD display to indicate abnormal condition as listed in Table 3-7.

Table 3- 7 Error Message

The error messages defined here should be corresponded to the error codes.

MSG Code	Error Description
MSG01	A loopback is in effect
MSG02	LCD operation is locked
MSG03	Channel is already in use
MSG04	Can't be in TTM if MCLK=DTE
MSG05	DTEn is in TTM or speed is 0
MSG06	Line not in sync
MSG07	No channel is assigned
MSG08	Please select speed first
MSG09	A test is in progress
MSG10	DTE loopback is in progress
MSG11	Please reduce speed first
MSG12	Illegal Date/Time format
MSG13	The DTE1 channel should be B2
MSG14	The DTE1 channel should be B1+B2
MSG15	The DTE1 channel should be B1
MSG16	The DTE1 channel should be B1/B2
MSG17	Remote doesn't have this function
MSG18	Remote unit rejected this request
MSG19	Remote unit didn't respond
MSG20	Remote DTE1 TTM should be off
MSG21	The DTE1 channel should be IDLE
MSG22	The DTE1 is not installed
MSG23	Undefined response
MSG24	The unit didn't response
MSG25	Speed can't be zero if MCLK=DTEn
MSG26	The unit is not installed
MSG27	ESF or ESF&T1.403 mode is required
MSG28	ESF&T1.403 mode is required
MSG29	E1 FDL and CRC must set to be on
MSG30	LLB or LOCAL LOOPBACK activated
MSG31	EOC is not ready
MSG32	Illegal value
MSG33	V54 is inactive
MSG34	Incorrect total channel
MSG35	Reserved for future use
MSG36	Reserved for future use
MSG37	Reserved for future use
MSG38	Reserved for future use
MSG39	Reserved for future use

3.18 Embedded SNMP Agent

The embedded SNMP agent, if installed, for Loop-V 4200 offers standard RFC 1213 MIB II and RFC 1406 DS1 MIB as well as Loop Telecom's enterprise MIB. Network manager can use any SNMP compatible network management system such as Sun Connect's Sun Net Manager and Hewlett-Packard's HP Open View to monitor and control Loop-V 4200 series. This enables user to integrate WAN equipment management with LAN SNMP network management systems. The embedded SNMP agent also includes Telnet implementation to allow user to access Loop-V 4200 terminal interface from any workstation in the network.



Figure 3- 2 SNMP Connection

Before SNMP is enabled, make sure the IP address for Loop-V 4200 is configured correctly and the communication parameters match the Terminal server port. The IP address is set in the System Configuration screen.

Once the SNMP agent is activated, user can verify whether the Loop-V 4200 is running successfully by using ping command to check if Loop-V 4200 series is responding or not. e.g.

```
$ ping 192.1.100.45
192.1.100.45 is alive
```

Please refer to each respective SNMP manager operation instruction to incorporate the Loop-V 4200 series enterprise MIB to the system.

Telnet capability comes with embedded SNMP agent. Once SNMP agent is running, user can use telnet program that is simulated a VT100 to access Loop-V 4200 command screen. The most popular Telnet utility in the public domain is provided by NCSA. **Only one user at a time can use telnet connection.** It is recommended to set the CONSOLE port running at the highest speed to reduce the jittery output on terminal. The Loop-V 4200 can run reliably at 38.4K bps.

3.19 Inband Management

Management of the Loop-V 4200 can be done through the LCD panel, the console port, the optional SNMP port or through the optional Router card with Subnet management (SNMC). Using the Router card, management of a local as well as remote Loop products (up to 32 inband management capable devices per card) is available.

A Network Management System (NMS) is connected to the Router card's Ethernet port. Using the TSI map, one channel is mapped to the unit's internal inband management port (HDLC port), and additional channels are mapped to T1/E1 time slots. These time slots must be sent to the remote unit, which does not require the Router card, which will map the incoming time slot to it's internal inband management port (HDLC port in the case of another 4200-9).

Chapter 3 Operation

Note: When you are setting the Inband Management configuration (see section 5.3. System Setup, System, Example 2, in this manual) a loopback timer will appear on your screen. If you are planning to do any loopback testing while in the Inband Management (HDLC) mode you must set the timer for a period (in seconds) suitable to your testing requirements. The inband management function will be unavailable for the duration of the loopback testing. If you are not planning to do any Loopback testing while in the Inband Management mode leave the timer at its default setting of "0" seconds.

The purpose of the timer is to prevent the irretrievable loss of your inband management line while doing loopback testing. When you are not in the inband management mode and wish to do loopback testing you can ignore the timer.

3.20 Port Backup

The Loop-V 4200 supports a one-for-one port protection based on the send on two, listen on one protection scheme. This allows protection of one port, and if one of the two ports are interrupted, the system automatically sends an alarm and switches to the second port.

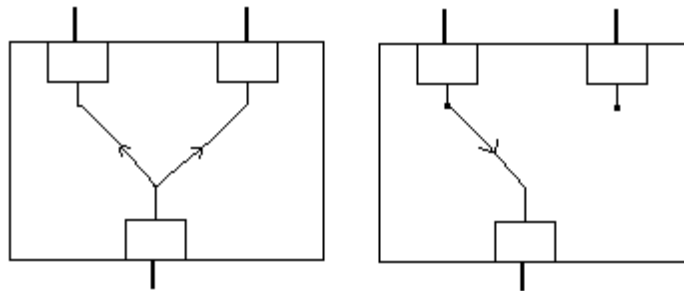

Send is to two different ports. Listen is from either of the two ports.

3.21 Verifying Loop-V 4200 Operations

The purpose of this section is not to help the user determine where a possible fault in the network may lie. For this, the user needs to know the exact geometry of the network. Then standard network trouble shooting procedures should be followed, which involve sectionalizing the network and performing loopback tests on pieces of the network.

The purpose here is to help the user determine whether the Loop-V 4200 equipment is at fault after tests have pointed a suspicious finger at this equipment. The procedures outlined here depends on test equipment and other equipment the user may have on hand.

The organization of these procedures start from the simple to the complex. The procedure ends when a definitive conclusion is made that the Loop-V 4200 equipment is at fault. To verify that the Loop-V 4200 equipment is not at fault, specialized equipment such as a BERT (bit error rate test) set is needed.

3.21.1 Quick Test

See if the LCD display on the Loop-V 4200 has normal text. If not, Loop-V 4200 has failed.

Remove all line connections to Loop-V 4200. Remove power. After a few seconds, re-apply power. Observe the power-up self-test sequence. If this fails, then Loop-V 4200 has failed.

See if the LEDs show any abnormal displays. If yes, use the LCD indications to guide the user to test other parts of the network.

Especially during initial installation, excessive errors may be due to (a) incorrect configuration of either Loop-V 4200 or of the equipment at the other end of the line, or (b) due to faulty line installation, which results in excessive noise, cross talk, or impedance mismatch. Especially in electrically noisy environments, such as central offices, use of shielded cables are mandatory.

3.21.2 Substitution

If a spare Loop-V 4200 is available, then replace the working one with the spare. The user must carefully configure the spare exactly as the working one. If the substitution clears the problem, then the original working one is suspect. Note that this is not definitive as other reasons may cause the same symptom. A good practice is to reconfigure the original one and swap once more.

If both units behave the same, then the problem is probably elsewhere.

3.21.3 Using Loopback Plugs

Without a spare, loopback plugs are handy for diagnosis. Note that internal loopback facilities of the Loop-V 4200 does not include the interface circuitry. Thus a set of plugs, one for each of the interfaces types, are needed for complete tests. These plugs are wired such that signals from the Loop-V 4200 are looped back by hard wire to the receive pin of the interface.

Replace the line connector with a loopback plug. Observe if the line is in sync. If not then Loop-V 4200 has failed. Then perform a PRBS/QRSS test towards the line. If this fails, then Loop-V 4200 has failed.

Note that if a far end terminal is available, the first test should be a local line loopback to see if the line is good.

If tests with loopback plugs all pass, then the problem is probably elsewhere.

4. FRONT PANEL OPERATION

The front panel operation utilizes a two by forty (2 x 40) character LCD display window and four keypads each labeled with **ESC**, **ENTER**, left arrow '<', and right arrow '>', as shown in Figure 4-1.

ENTER key is used to move down the menu tree or to enable a selection.

LEFT and RIGHT arrow keys show other menu item in the same level.

ESC key returns the operation to an upper layer menu up to the main menu.

NOTE: The **ENTER** key must be used to confirm a change. Where YES is shown at the lower right corner, it must be selected to enable a change.

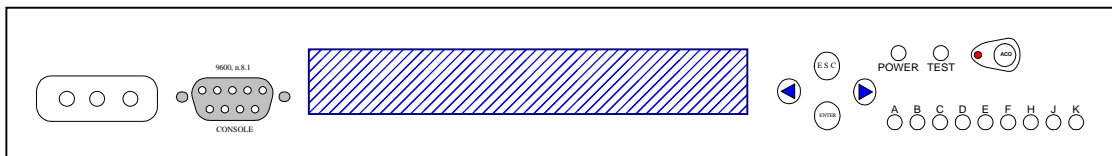

Figure 4- 1 Loop-V 4200 series Front Panel

Each display only shows one menu item. The main menu is shown in Figure 4-2. It is the first menu displayed after power up.

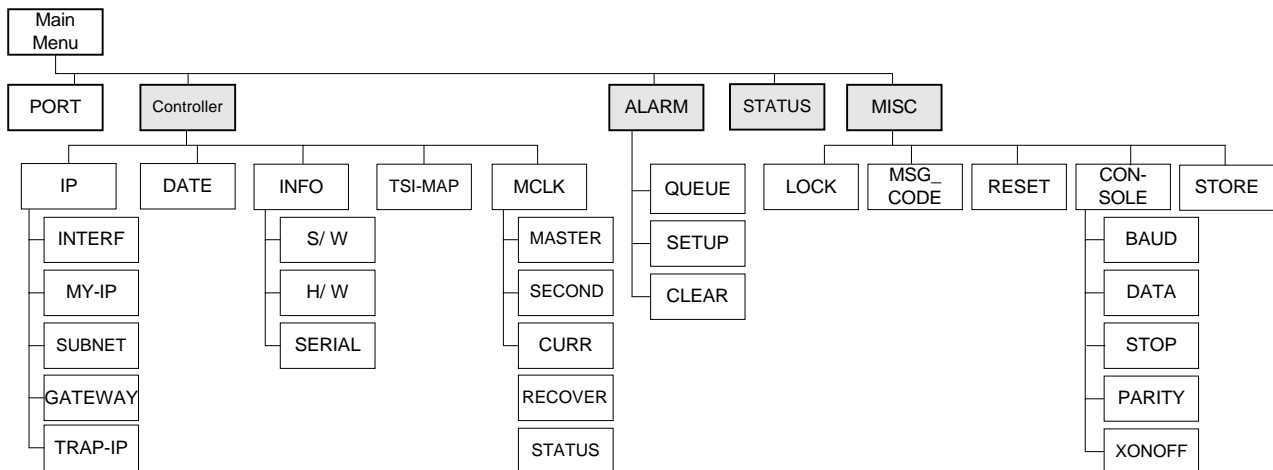

Figure 4- 2 Menu Tree

4.1 Port Menu

The main menu, the first menu displayed after power on, is shown below. The main menu of the Loop-V 4200 includes port, controller, alarm, status, and miscellaneous menus.

```
Loop V4200-9
<< PORT CONTROLLER ALARM STATUS MISC >>
```

4.1.1 DTE PORT

Use the arrow keys to select a port for the DTE interface card. In this case, port A.

```
PORT> Select Port: <DTE>
A B C D E F H J K
```

Other interface cards will look similar to this menu.

4.1.2 E1 PORT

Use the arrow keys to select a port for the E1 interface card. In this case, port B.

```
PORT> Select Port: <FE1>
A B C D E F H J K
```

4.1.3 T1 PORT

Use the arrow keys to select a port for the T1 interface card. In this case, port E.

```
PORT> Select Port: <FT1>
A B C D E F H J K
```

4.1.4 MDSL PORT

Use the arrow keys to select a port for the MDSL interface card. In this case, port H.

```
PORT> Select Port: <MDSL>
A B C D E F H J K
```

4.1.5 QFXS PORT

Use the arrow keys to select a port for the QFXS interface card. In this case, port H.

```
PORT> Select Port: <QFXS>  
A B C D E F H J K
```

4.1.6 QFXO PORT

Use the arrow keys to select a port for the QFXO interface card. In this case, port K.

```
PORT> Select Port: <QFXO>  
A B C D E F H J K
```

4.1.7 ROUTER PORT

Use the arrow keys to select a port for the Router interface card. In this case, port J.

```
PORT> Select Port: <RTR>  
A B C D E F H J K
```

4.1.8 T1 ATM/ FR PORT

Use the arrow keys to select a port for the T1 ATM/ FR interface card. In this case, port H.

```
PORT> Select Port: <ATM/FR>  
A B C D E F H J K
```

4.1.9 E1 ATM/ FR PORT

Use the arrow keys to select a port for the E1 ATM/ FR interface card. In this case, port H.

```
PORT> Select Port: <ATM/FR>  
A B C D E F H J K
```

4.2 CONTROLLER Menu

Press **ESC** to exit the "PORT" menu, then move the cursor to the "CONTROLLER" menu. Press **ENTER**.

```

Loop V4200-9
<<PORT CONTROLLER ALARM STATUS MISC >>
    
```

4.2.1 IP

The IP menu allows modification of the device IP address and the IP address used by the SNMP trap messages.

Each IP address can be modified by moving the cursor to the desired position and selecting a number. After making all changes, select YES to save the changes.

```

CONTROLLER>IP DATE INFO TSI-MAP MCLK
IP>INTERF MY-IP SUBNET GATEWAY TRAP-IP
    
```

```

IP>INTERF MY-IP SUBNET GATEWAY TRAP-IP
    *ETHERNET-PORT HDLC-PORT
    
```

Physical interfaces can be selected as HDLC-port for inband management and as Ethernet-port for Ethernet card management. Selection from this list of IP items is available by moving the cursor to the desired item and pressing **ENTER**, as for MY-IP below.

Modify the data by first pressing **ENTER**, which moves the cursor to the lower line, then move the cursor to the new selection and press **ENTER**. Press **ESC** to move up the menu tree.

To modify the IP addresses, first move the cursor to the digit to be modified. Press **ENTER**. Then move the cursor to the desired digit on the lower line. Press **ENTER**. When all the digits have been modified, move cursor the word "YES" and press **ENTER**.

The My IP Address menu shows the current IP address of the Loop-V 4200. To change the IP address, use the arrow keys to select the position, and press **ENTER** to cycle through the numbers. This operation must be concluded by moving the cursor to the OK position and pressing **ENTER** to enable the changes.

```

IP>INTERF MY-IP SUBNET GATEWAY TRAP-IP
    My IP Address= 140.132.25.25
    
```

```

IP>INTERF MY-IP SUBNET GATEWAY TRAP-IP
    My IP Subnet = 000.000.000.000
    
```

```

IP>INTERF MY-IP SUBNET GATEWAY TRAP-IP
    My IP Gateway = 000.000.000.000
    
```

Chapter 4 Front Panel Operation

Press **ENTER** from Console Port Trap IP menu

```
IP>INTERF MY-IP SUBNET GATEWAY TRAP-IP
      Trap IP Address= 255.255.255.255
```

The Trap IP Address menu shows the current destination IP address the Loop-V 4200 uses to send an SNMP trap. The default Trap IP address is a broadcast address (255.255.255.255). To change the Trap IP address, use the arrow keys to cycle through to the position, and press **ENTER** to cycle through the numbers. This operation must be concluded by moving the cursor to OK position and pressing **ENTER** to enable the changes.

NOTE: My IP and Trap IP menu only available when the SNMP feature is purchased.

4.2.2 DATE

The Date menu is used to set a new Real Time Clock (RTC) date. From the Configuration menu, use the cursor to select the Date menu. Press **ENTER** from Configuration Date menu

To change the date, use the arrow keys to move to the digital position, and press **ENTER** to cycle through the numbers. This operation must be concluded by moving the cursor to OK position and pressing **ENTER** to enable the changes.

```
CONTROLLER>IP DATE INFO TSI-MAP MCLK
      11:41:40 10/06/1998
```

```
DATE>11:42:20 10/06/1998 YES
      0123456789
```

4.2.3 INFO

This Information item displays the software version. It is a read only message.

```
CONTORLLER>IP DATE INFO TSI-MAP MCLK
INFO>S/W H/W SERIAL
```

```
INFO>S/W H/W SERIAL
Version: v0.07 10/01/1998
```

4.2.4 TSI-MAP

The TSI-Map menu is used to monitor the port assignment for each DS0 time slot.

```
CONTROLLER>IP DATE INFO TSI-MAP MCLK  
TSI-MAP>A B C D E F H J K Z
```

First, the port must be selected.

4.2.4.1 DTE PORT

From the Configuration menu, use the arrow keys to select TSI-Map menu. Then use the arrow keys to select the DTE device, in this case port A.

```
TSIMAP>Select Port:<DTE>  
A B C D E F H J K Z
```

After pressing **ENTER** from the above LCD, the following LCD will be displayed.

NOTE: TSI-MAP setting for DTE port must be set up from the first time slot. Then do the following time slots in sequence. Users are not allowed to set up the TSI-MAP for the DTE port by random settings.

```
MAP>[iiiiiiiiiiiiiiiiiiiiiiiiiiiiiiiiiiiiiii]  
A_01(DTE,d,NULL)<->IDLE
```

4.2.4.2 E1 PORT

From the Configuration menu, use the arrow keys to select the TSI-Map menu. Then use the arrow keys to select the E1 card, in this case port B.

```
TSIMAP>Select Port:<FE1>  
A B C D E F H J K Z
```

After pressing **ENTER** from the above LCD, the following LCD will be displayed.

```
MAP>[iiiiiiiiiiiiiiiiiiiiiiiiiiiiiiiiiiiiiii]  
B_01(FE1,d,NOCAS)<->IDLE
```

4.2.4.3 T1 PORT

From the Configuration menu, use the arrow keys to select the TSI-Map menu. Then use the arrow keys to select the T1 card, in this case port C.

```
TSIMAP>Select Port:<FT1>  
A B C D E F H J K Z
```

After pressing **ENTER** from the above LCD, the following LCD will be displayed.

```
MAP>[iiiiiiiiiiiiiiiiiiiiiiiiiiiiiiiiiiiiiii]  
C_01(FT1,d,NOCAS)<->IDLE
```

4.2.4.4 MDSL PORT

From the Configuration menu, use the arrow keys to select the TSI-Map menu. Then use the arrow keys to select the MDSL card, in this case, port H.

```
TSIMAP>Select Port:<MDSL>
A B C D E F H J K Z
```

After pressing **ENTER** from the above LCD, the following LCD will be displayed.

```
MAP>[iiiiiiiiiiiiiiiiiiiiiiiiiiiiiiiiiiiiii]
H_01(MDSL,d,NULL)<->IDLE
```

4.2.4.5 QFXS PORT

From the Configuration menu, use the arrow keys to select the TSI-Map menu. Then use the arrow keys to select the QFXS card, in this case, port E.

```
TSIMAP>Select Port:<QFXS>
A B C D E F H J K Z
```

After pressing **ENTER** from the above LCD, the following LCD will be displayed.

```
MAP>[iiii]
E_01(QFXS,d,NULL)<->IDLE
```

4.2.4.6 QFXO PORT

From the Configuration menu, use the arrow keys to select the TSI-Map menu. Then use the arrow keys to select the QFXO card, in this case, port E.

```
TSIMAP>Select Port:<QFXO>
A B C D E F H J K Z
```

After pressing **ENTER** from the above LCD, the following LCD will be displayed.

```
MAP>[iiii]
E_01(QFXO,d,NULL)<->IDLE
```

4.2.4.7 ATM/T1 PORT

From the Configuration menu, use the arrow keys to select the TSI-Map menu. Then use the arrow keys to select the T1 ATM/FR card, in this case, port E.

```
TSIMAP>Select Port:<ATM/FR>
A B C D E F H J K Z
```

After pressing **ENTER** from the above LCD, the following LCD will be displayed.

```
MAP>[i]
E_01(ATMT,d,NOCAS)<->IDLE
```

4.2.4.8 ATM/E1 PORT

From the Configuration menu, use the arrow keys to select the TSI-Map menu. Then use the arrow keys to select the E1 ATM/FR card, in this case, port F.

```
TSIMAP>Select Port:<ATM/FR>
A B C D E F H J K Z
```

After pressing **ENTER** from the above LCD, the following LCD will be displayed.

```
MAP>[i]
F_01(ATME,d,NOCAS)<->IDLE
```

4.2.4.9 Inband Management

From the Configuration menu, use the arrow keys to select the TSI-Map menu. Then use the arrow keys to select the inband management, port Z.

```
TSIMAP>Select Port:<INBAND>
A B C D E F H J K Z
```

Inband management stream, port Z, only supports DS0 (64K) mapping.

```
MAP>[i]
Z_01(INBN,d,NULL)<->H_01(FE1,d,NOCAS)
```

Chapter 4 Front Panel Operation

4.2.4.10 TSI-MAP SETUP

To change the TSI-MAP setup, use the arrow keys to select the desired option, and press **ENTER**. If the channel is idle, PORT menu must be displayed as "X", TIMESLOT menu must be displayed as "XX".

NOTE: Please verify the new configuration for TSI-MAP.

```
E01 SETUP>PORT TIMESLOT CH_TYPE CHANGE
          *X   *XX   *d
```

4.2.5 MCLK

Master clock menus are used to configure the master clock source and clock rate. From the Configuration menu, use the arrow keys to select the Master Clock menu.

```
CONTROLLER>IP DATE INFO TSI-MAP MCLK
MCLK>MASTER SECOND CURR RECOVER STATUS
```

4.2.5.1 MASTER CLOCK

NOTE: Secondary Clock Menu operation is similar.

Press **ENTER** from Master Clock Primary Clock

The Master clock menu shows the current clock source as INT (internal), Port A, B, C, D, E, F, H, J, K, EXT (external) by placing an asterisk (*) by the appropriate selection. To change the selection, move the cursor to the desired selection and press **ENTER**. The External-clock menu shows the current external clock rate in the lower left corner of the display. The rate of the external clock is 2.048 Mbps.

```
MCLK>MASTER SECOND CURR RECOVER STATUS
*INT.  A B C D E F H J K  EXT.
```

4.2.5.2 SECOND CLOCK

Use the right arrow key to select the "SECOND" menu, and press **ENTER**. The LCD will show as follows:

```
MCLK>MASTER SECOND CURR RECOVER STATUS
*INT.  A B C D E F H J K  EXT.
```

4.2.5.3 CURRENT ACTIVE CLOCK

The Current Active clock menu shows the current active clock source is PRIMARY master clock or 2nd master clock.

```
MCLK>MASTER SECOND CURR RECOVER STATUS
*MASTER_CLK  SECOND_CLK  INTERNAL
```

4.2.5.4 RECOVER

The Recover menu shows the master clock recover mode. If clock mode is automatic, the Loop-V 4200 will return to the master clock source in one minute after the master clock is recovered. The current active clock source is automatically changed to master clock.

```
MCLK>MASTER SECOND CURR RECOVER STATUS
MANUAL *AUTOMATIC
```

4.2.5.5 STATUS

The Status menu shows the status for the master clock.

```
MCLK>MASTER SECOND CURR RECOVER SSTATUS
NORMAL
```

4.3 ALARM

The Alarm menu is used to view the alarm queue and alarm history, to clear the alarm queue, alarm history, and alarm relay, as well as setup alarm threshold, etc..

```
Loop V4200-9
<< PORT CONTROLLER AALARM STATUS MISC >>
```

4.3.1 QUEUE

The Alarm Queue menu is used to view the alarm queue. From the Alarm menu, use the arrow keys to select Alarm Queue menu. Then press **ENTER**.

The alarm queue is a list of the latest 40 alarms from the unit selected. The upper right shows the alarm sequence and the total number of alarms. The lower left is the alarm type number. The lower right is the date and time of the alarm.

```
ALARM>QQUEUE SETUP CLEAR
QUEUE>NEXT PREV
```

```
QUEUE>NEXT PREV 00/00
Empty
```

4.3.2 SETUP

The Alarm Setup menu is used to set up the threshold level of each alarm type, and enable alarm relay and auto dial out function. Some types of alarm do not have threshold levels. From the Alarm menu, use the arrow keys to select Alarm Setup menu.

```
ALARM>QUEUE SETUP CLEAR
SETUP>NEXT PREV EDIT
```

```
SETUP>NEXT PREV EDIT 1
ALARM: *DISABLE ENABLE
```

4.3.3 CLEAR

The Alarm Clear menu is used to clear the alarm queue and history. From the Alarm menu, use the arrow keys to select Alarm Clear menu.

```
ALARM>QUEUE SETUP CLEAR
          Clear All Alarm? NO YES
```

4.4 STATUS

The status menu shows ports status.

```
LOOP V4200-9
<< PORT CONTROLLER ALARM STATUS MISC >>
```

```
A B C D E F H J K
I o o o * o o o o
```

4.5 Miscellaneous

The Miscellaneous menu includes lock, MSG Code, reset, console, and store.

```
Loop V4200-9
<< PORT CONTROLLER ALARM STATUS MISC >>
```

4.5.1 Lock

The Lock menu is used to control LCD panel operation. Normally, configuration can be changed from the front panel. Front panel configuration changes can be disabled by selecting the LOCK MENU. With a locked front panel, read only configuration information and line status can be obtained.

```
MISC>LOCK MSG_CODE RESET CONSOLE STORE
LOCK>Front Panel and Password
```

To disable the front panel lock, a password must be entered. Use the arrow keys to select a character. There are 66 possible characters to choose from. Password modification can only be done using terminal operation.

```
LOCK>Front Panel and Password
      *DISABLE ENABLE
```

4.5.2 MSG Code

The MSG-code menu shows error codes and error descriptions. Table 3-7 lists error codes and messages.

```
MISC>LOCK MSG_CODE RESET CONSOLE STORE
MESSAGE>NEXT PREV
```

```
ERROR>NEXT PREV 1
MSG01: A loopback is in effect
```

4.5.3 RESET

Select RESET to simulate a power up sequence including a self test of the controller as when power is first turned on. A password is required to effect this operation.

```
MISC>LOCK ERROR_CODE RESET CONSOLE STORE
RESET>Reset Controller
```

4.5.4 Console Port

These menus are used to configure the console port for data rate, data bits, stop bits, parity bit, XON-XOFF control, interface type, and SNMP control.

```
MISC>LOCK ERROR_CODE RESET CONSOLE STORE
CONSOLE>BAUD DATA STOP PARITY XONOFF
```

4.5.4.1 BAUD Rate

Press **ENTER** from Console Port Baud Rate menu. To change data speed, use the arrow keys to cycle through to a desired selection and press **ENTER**.

```
CONSOLE>BAUD DATA STOP PARITY XONOFF
38400 19200 *9600 4800 2400 1200
```

4.5.4.2 Data

Press **ENTER** from Console Port Data Length menu. To change data bits, use the arrow keys to cycle through to a desired selection and press **ENTER**.

```
CONSOLE>BAUD DATA STOP PARITY XONOFF
*8-Bits 7-Bits
```

4.5.4.3 STOP

Press **ENTER** from Console Port Stop Bit menu. To change stop bits, use the arrow keys to cycle through to a desired selection and press **ENTER**.

```
CONSOLE>BAUD DATA STOP PARITY XONOFF
*1-Bit 2-Bits
```

Chapter 4 Front Panel Operation

4.5.4.4 PARITY

Press **ENTER** from Console Port Parity menu. To change data parity, use the arrow keys to cycle through to a desired selection and press **ENTER**.

NOTE: Any changes to this setting will affect a terminal connected to the Console port.

```
CONSOLE>BAUD DATA STOP PARITY XONOFF
*NONE EVEN ODD
```

4.5.4.5 XONOFF

Press **ENTER** from Console Port Xon-Xoff. To change, use the arrow keys to cycle through to a desired selection and press **ENTER**.

NOTE: Xon-Xoff flow control will be terminated when SNMP mode is selected

```
CONSOLE>BAUD DATA STOP PARITY XONOFF
*OFF ON
```

4.5.5 Store

These menus are used to configure the console port for data rate, data bits, stop bits, parity bit, XON-XOFF control, interface type, and SNMP control.

```
MISC>LOCK ERROR_CODE RESET CONSOLE STORE
STORE>STORE RETRIEVE
```

4.5.5.1 Store

Under the STORE menu, move the cursor to STORE, then press **ENTER**. The LCD will show as below.

```
STORE>STORE RETRIEVE
STORING
```

4.5.5.2 Retrieve

Under the STORE menu, move the cursor to RETRIEVE, then press **ENTER**. The LCD will show as below.

```
STORE>STORE RETRIEVE
RETRIEVING
```

5. TERMINAL OPERATIONS

The Loop-V 4200 series provides comprehensive report and enhanced configuration capability through the console port on the front of the main unit. A VT100 type terminal can be connected to the console port, which is a standard RS232 interface. Using single-character commands and arrow keys, the Loop-V 4200 can be configured and monitored. The single-character commands are not case sensitive. On each screen, the available commands and the configurable fields are highlighted. Alarm messages are also sent to the console port and are shown on the top of the screen in a blinking mode. Upon power up, the main menu is shown.

NOTE: On the upper right corner of the screen, a time-of-day display indicates the time the current screen is shown. Any key, other than **ESC**, may be pressed to update the screen.

```

LOOP V4200-9          === Controller Menu ===          15:50:49 10/25/2001
Serial Number: 771   Connect_port: SUPV_PORT
Version           : HW H/W VER.E SW S3.Q4 05/24/2002
Start Time       : 15:35:17 06/25/2002             PWR1: active   PWR2: active
[Port Status]
A      B      C      D      E      F      H      J      K
FT1   FT1   FT1   FT1   FT1   FT1   FT1   2WE&M  4WE&M

[DISPLAY]
C -> Display System Configuration
Q -> Alarm Queue Summary
I -> Information Summary

[SETUP]
S -> System Setup
P -> Password Setup
M -> System Alarm Setup
L -> Firmware Download/Upload
T -> Configuration Download/Upload
V -> Store/Retrieve Configuration

[LOG]
U -> Choose a Unit
F -> Log Off [SETUP],[MISC] Menu
O -> Log On  [SETUP],[MISC] Menu

[MISC]
A -> Alarm Cut Off
X -> Clear Alarm Queue
Y -> Controller Return to Default
Z -> Controller Reset
K -> Load All Ports Default

>>SPACE key to refresh or enter a command ===>

```

5.1 System Configuration

Press "C" to view the system configuration. There are six choices for baud rate: 38400, 19200, 9600, 4800, 2400, and 1200.

```

LOOP V4200-9          === System Configuration ===      09:51:02 04/12/2001

[System]
IP Interface       : ETHERNET_PORT
IP Address         : 000.000.000.000 Subnet:000.000.000.000 Gateway:000.000.000.000
Trap IP Address   : 255.255.255.255
Community Name    : public
Device Name       : LOOP V4200-9
System Location   : 8F,No. 8,Hsin Ann Rd.
                  : Science-Based Industrial Park
                  : Hsinchu,30077 Taiwan

System Contact    : Name: FAE Tel:+886-3-5787696 Fax:+886-3-5787695
                  : E-mail:FAE@loop.com.tw

Baud Rate        : 9600          TSI_FUNC: 1:1(Bidirection)
Data Length      : 8-Bits
Stop Bit         : 1-Bit
Parity           : NONE
XON_XOFF        : XOFF

<< ESC key to return to previous menu, SPACE key to refresh >>

```

Chapter 5 Terminal Operation

5.2 Information Summary

Press "I" for the Information Summary screen.

```

LOOP V4200-9          === Information Summary ===          09:25:55 07/19/2000

Port Alarm  Interface              Software Version
A  0      FT1-LONG_HAUL             V1.15  12/18/1998
B  0      FE1-120ohm               V1.15  12/18/1998
C  0      DTE-V.35                 V1.06  11/30/1998
D
E
F
H
J
K

<< ESC key to return to previous menu, SPACE key to refresh >>

```

5.3 System Setup

Press "S" for the System Setup screen. Options from here offer MAP, PORT_BACKUP, SYSTEM, CLOCK. Use the arrow keys and press **ENTER** to select a setup item.

```

LOOP V4200-9          === System Setup ===                09:25:55 07/19/2000

>> Select System_setup Type ? *MAP  PORT_BACKUP  SYSTEM  CLOCK

```

When "MAP" is selected, the Time Slot Interchange screen appears.

NOTE: Before performing time slot assignment, please see section 3.12 about CAS configuration.

Example 1:

Use arrow keys to move the cursor, and TAB key to roll options.

```

LOOP V4200-9          === System Setup ( MAP ) ===        09:25:55 07/19/2000
ARROW KEYS: CURSOR MOVE, Please Input: 0~9, BACKSPACE to edit
  PORT A  PORT B  PORT C  PORT D  PORT E  PORT F  PORT H  PORT J  PORT K  PORT Z
TIME FE1   FE1   FE1   FE1   FT1   FXO   FXS   DTE   DTE   INBAND
SLOT NONCAS NONCAS CAS   CAS   NONCAS A-LAW A-LAW V.35  V.35
=====
 1  d  J  01  d  B  01  d   00  v  F  01  d   00  v  D  01  v  C  03  d  A  01  d  A  03  d   00
 2  d   00  d  B  02  d  J  02  v  F  02  d   00  v  D  02  v  C  04  d  C  02  d  A  04  d   00
 3  d  K  01  d  B  03  v  H  01  v  F  03  d   J  03  v  D  03           d  E  03  d   03  d   00
 4  d  K  02  d  B  04  v  H  02  v  F  04  d   00  v  D  04           d   00  d   00  d   00
 5  d   00  d  B  05  d   00  d  D  05  d   00           d   00  d   00  d   00
 6  d   00  d  B  06  d   00  d  D  06  d   00           d   00  d   00  d   00
 7  d   00  d  B  07  d   00  d  D  07  d   00           d   00  d   00  d   00
 8  d   00  d  B  08  d   00  d  D  08  d   00           d   00  d   00  d   00
 9  d   00  d  B  09  d   00  d  D  09  d   00           d   00  d   00  d   00
10  d   00  d  B  10  d   00  d  D  10  d   00           d   00  d   00  d   00
11  d   00  d  B  11  d   00  d  D  11  d   00           d   00  d   00  d   00
12  d   00  d  B  12  d   00  d  D  12  d   00           d   00  d   00  d   00
13  d   00  d  B  13  d   00  d  D  13  d   00           d   00  d   00  d   00
14  d   00  d  B  14  d   00  d  D  14  d   00           d   00  d   00  d   00
15  d   00  d  B  15  d   00  d  D  15  d   00           d   00  d   00  d   00
16  d   00  d  B  16  s   00  s   00  d   00           d   00  d   00  d   00

<< ESC key to previous menu, SPACE key to another page >>          PAGE1

```

Chapter 5 Terminal Operation

In the above screen, Time Slot number applies to originating time slot of all ports. The "d" means the time slot is assigned for data channel, "v" means for voice channel, "s" means for signaling channel. If time slot carries voice, A-law to μ -law conversion is automatic. Under PORT A, "NONCAS" means CAS (carrier associated signaling) is not used. Under PORT D, "v F 02" means that time slot 02 of PORT D, which carries voice, is assigned to time slot 02 of PORT F.

The above example is the first page of System Setup (MAP) screen, which displays 01 to 16 time slots. Use SPACE key to view the second page of System Setup (MAP) screen, which shows 17 to 31 time slots.

As for PORT D, "FE1 CAS" means that CAS is chosen for an E1 port, because time slot 16 is already assigned to signaling channel, a warning message will show up and the assignment will be ignored if user tries to use time slot 16 to carry data or voice. Thus time slots 01 to 15 (PAGE1) and 17 to 24 (PAGE2) are available assigned to data or voice channel.

Under PORT E, "FT1 NONCAS" means that CAS is not chosen for T1 port, thus time slots 01 to 16 (PAGE1) and 17 to 24 (PAGE2) are available assigned to data or voice channel.

Under PORT J, "DTE V.35" means the port type is DTE (V.35), thus time slots 01 to 16 (PAGE1) and 17 to 31 (PAGE2) are available for assignment.

NOTE: When a time slot from a CAS part is assigned to a NON-CAS port, all CAS signaling information is lost. Therefore, such assignments are usually made for time slots carrying data.

To change any of the MAP settings, use the arrow keys to move the cursor to the desired field and then modify that field. Modification of fields is either (a) by using the TAB key to cycle through the options, or (b) for time-slot assignment, by using backspace to erase and by using the numeric keys to enter a new number. For example, when the cursor is at the target port field, pressing the TAB key will cycle the target port or blank, which indicates idle assignment. When the target port is blank, the time-slot is 00. When the cursor is at the target time-slot field, user can enter a new last digit, or use the BACKSPACE key first to enter both digits.

When the user enters a new time-slot assignment, and if the target port and time slot is idle, then the reciprocal assignment is automatically made when the user moves the cursor away from that field. However, if the target port is not idle but already a part of a pair of time slots previously assigned, then that pair of assignments will flash to warn the user of possible conflicts. If the user chose to ignore the flashing warning and move the cursor away from the field with the desired assignment, then the new target port and time-slot will be changed to reflect the new reciprocal assignment. The third time slot, the other half of the previously assigned pair will be changed to idle.

Example 2:

```

LOOP V4200-9          === System Setup ( MAP ) ===          10:49:18 03/23/2000
ARROW KEYS: CURSOR MOVE, TAB: ROLL OPTIONS
  PORT A  PORT B  PORT C  PORT D  PORT E  PORT F  PORT H  PORT J  PORT K  PORT Z
TIME     FE1     FT1     DTE     MDSL     MDSL     MDSL     INBAND
SLOT     NONCAS  NONCAS  V.35
=====
 1      d K 01 d H 01 d J 01 d E 01 d F 01 d D 01 d H 01
 2      d K 02 d H 02 d J 02 d E 02 d F 02 d D 02 d   00
 3      d K 03 d   00 d J 03 d   00 d F 03 d D 03 d   00
 4      d K 04 d   00 d J 04 d   00 d F 04 d D 04 d   00
 5      d K 05 d   00 d J 05 d   00 d F 05 d D 05 d   00
 6      d K 06 d   00 d J 06 d   00 d F 06 d D 06 d   00
 7      d K 07 d   00 d J 07 d   00 d F 07 d D 07 d   00
 8      d K 08 d   00 d J 08 d   00 d F 08 d D 08 d   00
 9      d K 09 d   00 d J 09 d   00 d F 09 d D 09 d   00
10      d K 10 d   00 d J 10 d   00 d F 10 d D 10 d   00
11      d K 11 d   00 d J 11 d   00 d F 11 d D 11 d   00
12      d K 12 d   00 d J 12 d   00 d F 12 d D 12 d   00
13      d K 13 d   00 d   00 d   00 d   00 d D 13 d   00
14      d K 14 d   00 d   00 d   00 d   00 d D 14 d   00
15      d K 15 d   00 d   00 d   00 d   00 d D 15 d   00
16      d K 16 d   00 d   00 d   00 d   00 d D 16 d   00
<< ESC key to previous menu, SPACE key to another page >>  K 01 >d D 01  PAGE1

```

Chapter 5 Terminal Operation

Example 3:

```

LOOP V4200-9          === System Setup ( MAP ) ===          10:47:33 07/19/2000
ARROW KEYS: CURSOR MOVE, Please Input: 0~9, BACKSPACE to edit
  PORT A PORT B PORT C PORT D PORT E PORT F PORT H PORT J PORT K PORT Z
TIME      ATM/FR          ATM/FR FE1          INBAND
SLOT     NONCAS          NONCAS NONCAS
=====
 1         d   00          d   00 d Z 01          d H 01
 2         d   00          d   00 d   00          d   00
 3         d   00          d   00 d   00          d   00
 4         d   00          d   00 d   00          d   00
 5         d   00          d   00 d   00          d   00
 6         d   00          d   00 d   00          d   00
 7         d   00          d   00 d   00          d   00
 8         d   00          d   00 d   00          d   00
 9         d   00          d   00 d   00          d   00
10        d   00          d   00 d   00          d   00
11        d   00          d   00 d   00          d   00
12        d   00          d   00 d   00          d   00
13        d   00          d   00 d   00          d   00
14        d   00          d   00 d   00          d   00
15        d   00          d   00 d   00          d   00
16        d   00          d   00 d   00          d   00

<<ESC key to previous menu, SPACE key to another page >>          PAGE1

```

When "PORT_BACKUP" is selected, the following screen appears.

Example 1:

```

LOOP V4200-9          === System Setup ( BACKUP ) ===        10:47:58 07/19/2000
ARROW KEYS: CURSOR MOVE, TAB: ROLL OPTIONS
  PORT A PORT B PORT C PORT D PORT E PORT F PORT H PORT J PORT K PORT Z
T1      E1      DTE          INBAND
BACK NONCAS NONCAS V.35
UP  =====
BY

<< Press ESC key to return to previous menu >>

```

Chapter 5 Terminal Operation

Example 2:

```
LOOP V4200-9          === System Setup ( BACKUP ) ===      10:47:58 07/19/2000
ARROW KEYS: CURSOR MOVE, TAB: ROLL OPTIONS
  PORT A PORT B PORT C PORT D PORT E PORT F PORT H PORT J PORT K PORT Z
BACK                ATM/FR                ATM/FR FE1                INBAND
UP                NONCAS                NONCAS NONCAS
BY                =====
<< Press ESC key to return to previous menu >>
```

When "SYSTEM" is selected, the following screen appears.

Example 1:

```
LOOP V4200-9          === System Setup (SYSTEM) ===      15:50:25 10/25/2001
ARROW KEYS: CURSOR MOVE, TAB: ROLL OPTIONS
[System]
Time/Date           :15:50:07 10/25/2001
IP Interface        :ETHERNET_PORT
IP Address          :140.132.001.137 Subnet:255.255.255.192 Gateway:210.061.247.129
Trap IP Address    :255.255.255.255
Community Name     :public
Device Name        :LOOP V4200-9
System Location    :8F,No. 8,Hsin Ann Rd.
                   Science-Based Industrial Park
                   Hsinchu,30077 Taiwan
System Contact     :Name: FAE Tel:+886-3-5787696 Fax:+886-3-5787695
                   E-mail:F AE@loop.com.tw
Baud Rate          : 9600          TSI_FUNC: 1:1(Bidirection)
Data Length       : 8-Bits
Stop Bit          : 1-Bit
Parity            : NONE
XON_XOFF          : XOFF
>> Change configuration (Y/N)? (Note:If Change TSI_FUNC,All XC will be dropped)
```

Chapter 5 Terminal Operation

Example 2:

As the following screen shows, when IP interface is HDLC_PORT, the system will request to enter loopback time (in second) option. Move the cursor to the "Loopback Timer" option, then key in the desired time.

NOTE: If you are not planning to do any loopback testing while in the Inband Management(HDLC) mode leave the timer at its default setting of "0" seconds For more information please refer to section 3.19 Inband Management, in this manual

```
LOOP V4200-9          === System Setup (SYSTEM) ===          15:50:25 03/01/2002
ARROW KEYS: CURSOR MOVE, Please Input: hh:mm:ss mm/dd/yyyy, BACKSPACE to edit
[System]
Time/Date           :15:50:07 10/25/2001
IP Interface        :HDLC_PORT          Loopback Timer (s) : 00018427
IP Address          :140.133.001.137 Subnet:255.255.000.000 Gateway:000.000.000.000
Trap IP Address    :255.255.255.255
Community Name     :public
Device Name        :LOOP V4200-9
System Location    :8F,No. 8,Hsin Ann Rd.
                   :Science-Based Industrial Park
                   :Hsinchu,30077 Taiwan

System Contact     :Name: FAE Tel:+886-3-5787696 Fax:+886-3-5787695
                   :E-mail:F AE@loop.com.tw

Baud Rate          : 9600          TSI_FUNC: 1:1(Bidirection)
Data Length        : 8-Bits
Stop Bit           : 1-Bit
Parity             : NONE
XON_XOFF           : XOFF

<< Press ESC key to return to previous menu >>
```

When "CLOCK" is selected, the following screen appears. There are nine choices for Master_Clk Source and Second_Clk: PORT_A to PORT_F, PORT_H, PORT_J, and PORT_K. Two choice for Master_Clk Source and Second_Clk Source, and INTERNAL, are available.

```
LOOP V4200-9          === System Setup (CLOCK) ===          09:25:55 07/19/2000
ARROW KEYS: CURSOR MOVE, TAB: ROLL OPTIONS

Master_Clk Source  : PORT_C
Second_Clk Source  : INTERNAL
Current Clock      : MASTER_CLK
Clk_Recover_mode   : AUTOMATIC
Clock Status       : NORMAL

<< Press ESC key to return to previous menu >>
```

5.4 Password Setup

Press "P" to change and enable the password setup.

```
LOOP V4200-9          === Password Setup ===          09:25:55 07/19/2000
ARROW KEYS: CURSOR MOVE, TAB: ROLL OPTIONS

Enable Password   : NO
Change Password   : NO

<< Press ESC key to return to previous menu >>
```

5.5 System Alarm Setup

Press "M" to change and enable the alarm setup.

```
LOOP V4200-9      === System Alarm Setup ===      09:25:55 07/19/2000
ARROW KEYS: CURSOR MOVE, TAB: ROLL OPTIONS

[Alarm Action]
ALARM           : DISABLE
RELAY           : DISABLE

[Alarm Type]
ALARM CUT OFF  : DISABLE
PORT INACTIVE  : DISABLE
PORT START-UP  : DISABLE
CLK LOSS ALM   : DISABLE

<< Press ESC key to return to previous menu >>
```

5.6 Firmware Download

Press "L" to change the version of controller firmware. Move the cursor to "DOWNLOAD". The current selection will be highlighted by an asterisk (*).

```
LOOP V4200-9      ===Download/Upload Firmware ===  17:34:36 04/19/2001

>> Select ?    *DOWNLOAD  UPLOAD
```

Press ENTER from the above screen. The following screen will show.

```
LOOP V4200-9      === Download Firmware ===      09:25:55 07/19/2000
ARROW KEYS: CURSOR MOVE, Please Input: nnn.nnn.nnn.nnn, BACKSPACE to edit

Current Software Ver.: V1.18 02/04/1999
Current Firmware Bank: 2
NextBootFirmware Bank: 2
TFTP Server IP      : 000.000.000.000
Firmware File Name  :

<< Press ESC key to return to previous menu >>
```

Chapter 5 Terminal Operation

5.7 Firmware Upload

Press "L" to change the version of controller firmware. Move the cursor to "UPLOAD". The current selection will be highlighted by an asterisk (*).

```
LOOP V4200-9          ===Download/Upload Firmware ===          17:34:36 04/19/2001

>> Select ?   DOWNLOAD   *UPLOAD
```

Press ENTER from the above screen. The following screen will show.

```
LOOP V4200-9          === Upload Firmware ===                   09:25:55 07/19/2000
ARROW KEYS: CURSOR MOVE, Please Input: nnn.nnn.nnn.nnn, BACKSPACE to edit

Current Software Ver.: V1.18 02/04/1999
Current Firmware Bank: 2
NextBootFirmware Bank: 2
TFTP Server IP       : 000.000.000.000
Firmware File Name   :
Firmware Bank Number : 1

<< Press ESC key to return to previous menu >>
```

5.8 Firmware Download/ Upload Procedure

This LoopV4200 controller software is flash memory based and allows software updates or download/uploads through the Ethernet port, as shown in Figures 5-1 and 5-2.

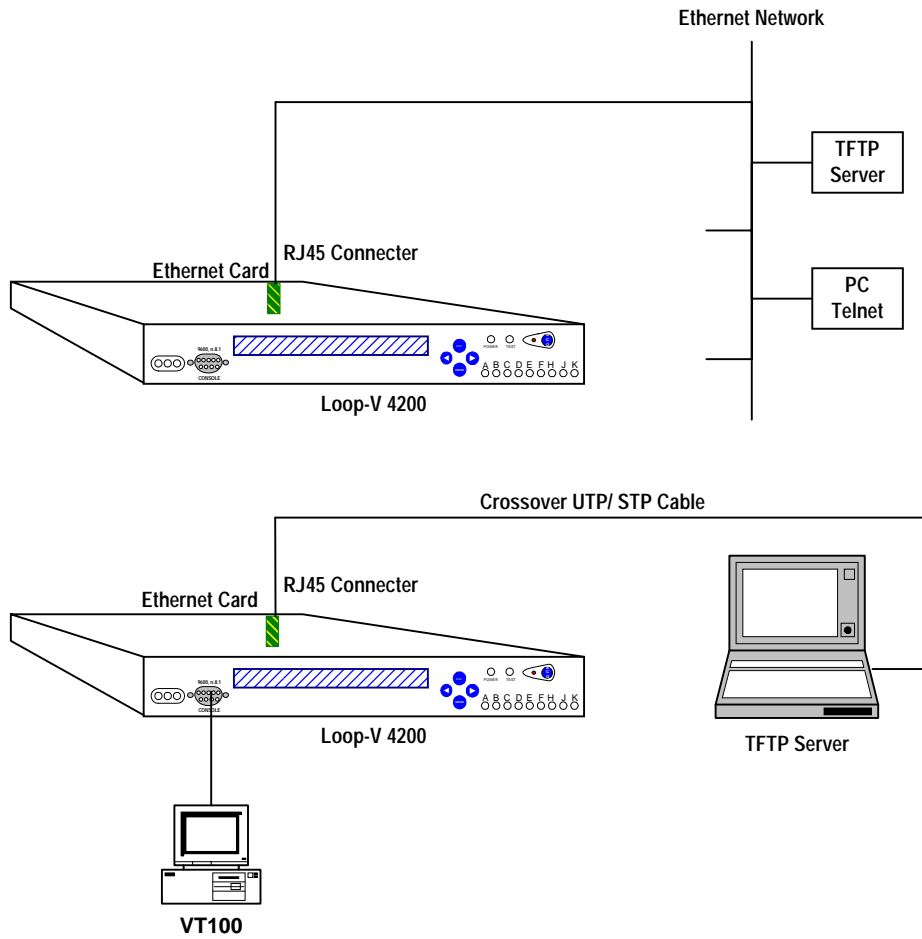

Figure 5- 1 Software Download Operation Setup - separate PC

Chapter 5 Terminal Operation

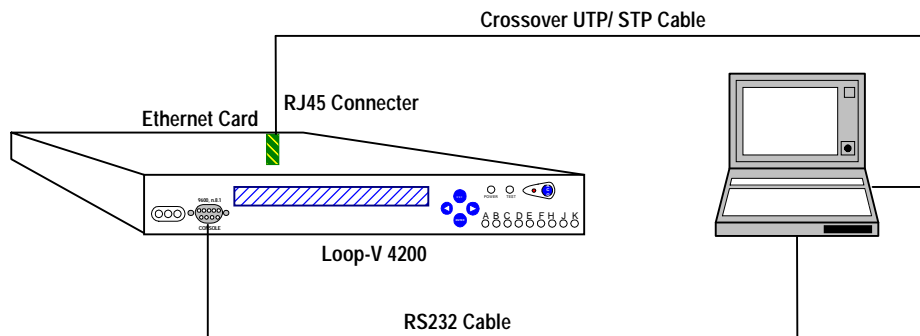

Figure 5- 2 Software Download Operation Setup - single PC

Equipment needed

- (1) Loop-V 4200 equipped with SNMP (Ethernet Card).
- (2) TFTP Server – This is a PC running TFTP software. To insure compatibility, use the TFTP copy supplied by Loop. This PC should have an Ethernet port (PCMCIA card for LAN connection). The server should have an IP address assigned. See your MIS manager if not assigned.
Note: One TFTP can simultaneously download to several Loop-V 4200.
- (3) VT100 Terminal – This can be a PC running VT100 emulation software. This PC should have an RS232 port. This can be the same PC as above server running concurrent programs of TFTP and VT100 emulation, Figure 5-2.
- (4) Ethernet line – As shown in Figure 5-1, either an Ethernet network or a crossover cable can be used to connect the TFTP server to the Loop-V 4200.

The download procedure is as follows:

- A. Connect the SNMP (Ethernet) of the Loop-V 4200 to the TFTP server Ethernet port.

NOTE: Use straight Ethernet cable if an Ethernet Hub is used. Use a cross-over Ethernet cable for a direct connection from TFTP server to the Loop-V 4200.

- B. Run the TFTP program. A screen will be shown with the server IP address displayed.
- C. Hook-up the COM PORT 1 of the VT100 (PC running VT100 emulation) to the Loop-V 4200 through the front console port.
- D. Run a VT100 terminal or TELNET program after connecting to the Loop-V 4200. A TELNET terminal will show screens similar to the VT100.
- E. From the main menu, press “L”, then select DOWNLOAD of controller firmware.
- F. Enter the proper TFTP Server IP address and the firmware file name (file to be download). Note: If the TFTP program and the firmware reside on separate volumes (hard disks), enter the complete file address including volume prefix, i.e. C:/file/name for hard disk, A:/file/name for floppy disk.
- G. Press ESC and confirm with Y.
Note: The new downloaded firmware is not effective until the controller is rebooted.
- H. If the specified firmware was downloaded successfully, the following message is displayed:

```
15:57:20 5/28/01   Downloading Firmware ... Receive 1533 Blocks
15:59:58 5/28/01   Check sum ok
15:59:58 5/28/01   Received 786432 bytes in 159 seconds
```

Chapter 5 Terminal Operation

- I. Reboot the controller after the software download. The reboot will implement the new firmware. If there is problem running the new downloaded firmware, it is possible to revert to the previous version firmware by pressing the LEFT & RIGHT keys simultaneously while powering on.

The upload procedure is similar to the download procedure:

- A. Connect the Loop-V 4200 to the TFTP server through the Ethernet port located in the back of the device.

NOTE: Use straight Ethernet cable if an Ethernet Hub is used. Use a cross-over Ethernet cable for a direct connection from TFTP server to the Loop-V 4200.

- B. Run the TFTP program. A screen will be shown with the server IP address displayed.
- C. Hook-up the COM PORT 1 of the VT100 (PC running VT100 emulation) to the Loop-V 4200 through the front console port.
- D. Run a VT100 terminal or TELNET program after connecting to the Loop-V 4200. A TELNET terminal will show screens similar to the VT100.
- E. From the main menu, press "L", then select UPLOAD of controller firmware.
- F. ENTER the proper TFTP Server IP address and firmware file name (file to be upload). Note: If the TFTP program and the firmware reside on separate volumes (hard disks), enter the complete file address including volume prefix, i.e. C:/file/name for hard disk, A:/file/name for floppy.
- G. Press ESC and confirm with Y.
- H. If the specified firmware was uploaded successfully, the following message is displayed:

```
15:55:12 5/28/01      Uploading Firmware ... Send 1536 Blocks
15:56:29 5/28/01      Sent 786432 bytes in 78 seconds
```

5.9 Configuration Download/ Upload

After configuration downloads, the configuration for each plug-in card would be as follows. If any plug-in card in any position is different type, factory default configuration is automatically downloaded to the new card. If any plug-in card in any position is the same type, depending on card type, then the following happens:

- For E1, T1, and DTE plug-in cards, the previous configuration is automatically downloaded.
- For Router plug-in card, the factory default configuration is assigned to the new card.
- For E1/ T1 ATM Frame Relay plug-in card, (a) The port configuration for E1 or T1 is automatically downloaded, (b) The Frame Relay management setup is factory default configuration.

Under the "Controller Menu", press "T" to enter in the "Download/ Upload SysConfig" screen. Then move the cursor to select DOWNLOAD to setup system configuration. The current selection will be highlighted by an asterisk (*).

5.9.1 Download Configuration

```
LOOP V4200-9          ===Download/Upload SysConfig===      17:34:36 04/19/2001

>> Select ?   *DOWNLOAD   UPLOAD
```

Press ENTER from the above screen. The following screen will show.

```
LOOP V4200-9          === Download SysConfig ===          15:52:06 10/25/2001
ARROW KEYS: CURSOR MOVE, BACKSPACE to edit, ESC to abort

TFTP Server IP       : 140.132.001.136
SysConfig File Name  : 09.CFG_____

<< Press ESC key to abort, ENTER key to continue >>
```

```
LOOP V4200-9          === Download SysConfig ===          15:54:20 10/25/2001
ARROW KEYS: CURSOR MOVE, BACKSPACE to edit, ESC to abort

TFTP Server IP       : 140.132.001.136
SysConfig File Name  : 09.CFG

      15:53:42 10/25/01  Downloading SysConfig...Recieved      384 Blocks
      15:54:05 10/25/01  check sum ok
      15:54:05 10/25/01  Validation ok
      15:54:06 10/25/01  Waiting...
      15:54:20 10/25/01  Download Success
      15:54:20 10/25/01  Received 196608 bytes in 39 seconds

<< Press ESC key to abort, ENTER key to continue >>
```

Chapter 5 Terminal Operation

5.9.2 Upload Configuration

Under the "Controller Menu", press "T" to enter in the "Download/ Upload SysConfig" screen. Then move the cursor to select DOWNLOAD to setup system configuration. Press ENTER. The current selection will be highlighted by an asterisk (*).

```
LOOP V4200-9          ===Download/Upload SysConfig===      17:34:59 04/19/2001

>> Select ?      DOWNLOAD *UPLOAD
```

Press ENTER from the above screen. The following screen will show.

```
LOOP V4200-9          === Upload SysConfig ===            15:51:29 10/25/2001
ARROW KEYS: CURSOR MOVE, BACKSPACE to edit, ESC to abort

TFTP Server IP       : 140.132.1.136
SysConfig File Name  : 09.CFG_____

<< Press ESC key to abort, ENTER key to continue >>
```

```
LOOP V4200-9          === Upload SysConfig ===            15:51:57 10/25/2001
ARROW KEYS: CURSOR MOVE, BACKSPACE to edit, ESC to abort

TFTP Server IP       : 140.132.1.136
SysConfig File Name  : 09.CFG

      15:51:38 10/25/01  Uploading SysConfig...  Sended    384 Blocks
      15:51:57 10/25/01  Sent 196608 bytes in 20 seconds

<< Press ESC key to abort, ENTER key to continue >>
```

5.10 Store/ Retrieve Configuration

Under the "Controller Menu", press "V" to enter in the "Store/ Retrieve Configuration" screen. Move the cursor to select RETRIEVE to retrieve the configuration or STORE to store the configuration. Press "Y" or "N" to confirm it. The current selection will be highlighted by an asterisk (*). Then press ENTER.

5.10.1 Retrieve Configuration

```
LOOP V4200-9          ===Store/Retrieve Configuration===      11:07:34 04/20/2001

>> Select ?      STORE      *RETRIEVE
>> Retrieve Last Stored Configuration ? [Y/N]
```

5.10.2 Store Configuration

```
LOOP V4200-9          ===Store/Retrieve Configuration===      11:06:58 04/20/2001

>> Select ?      *STORE      RETRIEVE
```

```
LOOP V4200-9          ===Store/Retrieve Configuration===      11:07:24 04/20/2001

>> Select ?      *STORE      RETRIEVE
>> Store Current Configuration ? [Y/N]
```

5.11 Configuration Download/ Upload Procedure

This LoopV4200 configuration software is similar to the firmware download procedure. See Section 5.8 for connection and equipment.

The download procedure is as follows:

A. Connect the SNMP (Ethernet) of the Loop-V 4200 to the TFTP server Ethernet port.

NOTE: Use straight Ethernet cable if an Ethernet Hub is used. Use a cross-over Ethernet cable for a direct connection from TFTP server to the Loop-V 4200.

B. Run the TFTP program. A screen will be shown with the server IP address displayed.

C. Hook-up the COM PORT 1 of the VT100 (PC running VT100 emulation) to the Loop-V 4200 through the front console port.

D. Run a VT100 terminal or TELNET program after connecting to the Loop-V 4200. A TELNET terminal will show screens similar to the VT100.

E. From the main menu, press "T", then select DOWNLOAD.

F. Enter the proper TFTP Server IP address and the firmware file name (file to be download). Note: If the TFTP program and the firmware reside on separate volumes (hard disks), enter the complete file address including volume prefix, i.e. C:/file/name for hard disk, A:/file/name for floppy disk.

G. Press ESC. After a question, "Really want to download? [Y/N)", shows on the screen, press "Y" to confirm the download.

H. When the message, "received bytes...", shows up, the download is done.

I. Press ESC to revert to the "Download/ Upload System Config." screen.

J. Press ESC to return to the "Controller Menu" screen.

K. Press "R" to retrieve the controller.

L. Under the "Store/ Retrieve Configuration" screen, move the cursor to RETRIEVE, then press ENTER. Press "Y" to retrieve last stored configuration. Then the system will show "Retrieving..." on the screen.

M. After the retrieve configuration is done, the system will return to the "Store/ Retrieve Configuration" screen. In the same screen, move the cursor to STORE, then press ENTER. press "Y" to store current configuration. Then the system will show "Storing..." on the screen.

NOTE: A configuration download file includes parameters contained in the "SYSTEM" screen. Those parameters related to the management channel might not be appropriate for the particular V4200-9 system. Such parameters are IP Interface, IP Address, Subnet, Gateway, Trap IP address, and Community Name. If these parameters in the download file are allowed to replace the original parameters of the V4200-9 system, the management connection could be lost. Therefore, in the above procedure, the steps of "RETRIEVE" configuration followed by "STORE" configuration will preserve these parameters in its original.

If the user intends to substitute some or all these parameters in the original system by those within the download file, then replace the steps RETRIEVE and STORE with Controller Reset, "Z". Final editing of the SYSTEM screen should follow Reset.

After the DOWNLOAD CONFIGURATION procedure, the PASSWORD of the 4200-9 system will be changed to that in the download file. Use the new downloaded password for all subsequent operations requiring a password.

The Download Configuration procedure allows the user to copy the configuration from a properly configured "master" 4200-9 system to one or more of other similar systems. However, these other systems must have identical hardware complement for the download to succeed. That is to say, each of the other systems must have same type plug-in modules installed in each of the available slots of the 4200-9 systems as the master system from which the download file was uploaded.

Chapter 5 Terminal Operation

The upload procedure is similar to the download procedure:

A. Connect the Loop-V 4200 to the TFTP server through the Ethernet port located in the back of the device.

NOTE: Use straight Ethernet cable if an Ethernet Hub is used. Use a cross-over Ethernet cable for a direct connection from TFTP server to the Loop-V 4200.

B. Run the TFTP program. A screen will be shown with the server IP address displayed.

I. Hook-up the COM PORT 1 of the VT100 (PC running VT100 emulation) to the Loop-V 4200 through the front console port.

J. Run a VT100 terminal or TELNET program after connecting to the Loop-V 4200. A TELNET terminal will show screens similar to the VT100.

K. From the main menu, press "T", then select UPLOAD of controller firmware.

L. ENTER the proper TFTP Server IP address and firmware file name (file to be upload). Note: If the TFTP program and the firmware reside on separate volumes (hard disks), enter the complete file address including volume prefix, i.e. C:/file/name for hard disk, A:/file/name for floppy.

M. Press ESC and confirm with Y.

6. Appendix A: Multicast/ Broadcast and Backup

Multicast/ Broadcast and Backup

This document is an addendum to the Loop-V 4200-9 manual. It covers the multicast/broadcast function of the Time Slot Interchange (TSI) capabilities of the 4200-9 chassis. For the purposes of this document, Multicast is an operation where one time slot is mapped to many time slots either on one or many DS1s (T1/E1 lines). Broadcast is the mapping of one time slot to all time slots of a single DS1.

This document will also cover the backup feature offered in the Loop-V 4200-9, which is a standard feature of this product. The backup functionality is also listed in the manual, but is mentioned here for clarity.

In this demonstration, Time Slot 1 of an E1 line, Port C, will be mapped to all 31 time slots of another E1 line, Port E. Port B, an E1 line, will serve as a backup to Port A. See the diagram below.

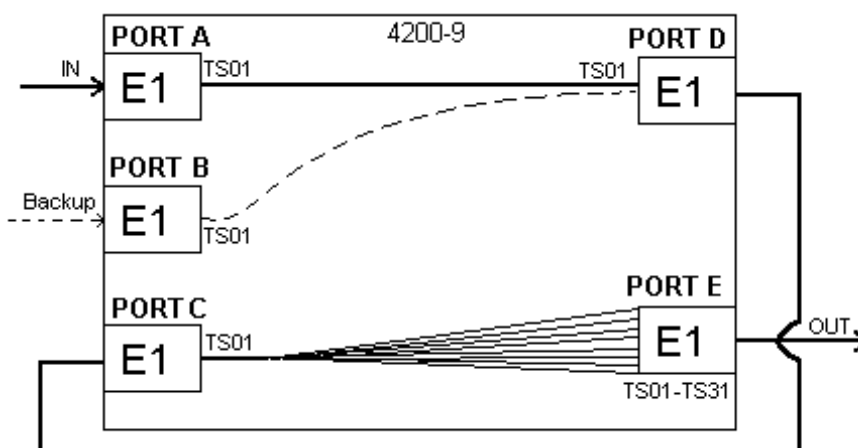

The Loop-V 4200 showing multicasting of Port C to Port E and backup of Port A by Port B

Hardware

Install an E1 card into Ports A, B, C, D, E.

Install an E1 cross-over cable from Port C to Port D.

Install a VT-100 terminal into the "Console" port on the front of the Loop-V 4200-9.

Appendix A

Configuration

The multicast function is setup in two places. First the Multicast function must be enabled.

From the main menu, press "S" for System setup.

```
LOOP V4200-9          === Controller Menu ===          10:48:35 09/06/2000
Serial Number: 10001  Connect_port: SUPV_PORT
Version       : HW H/W VER.E SW S3.Q4 05/24/2002
Start Time   : 15:35:17 06/25/2002          PWR1: active   PWR2: active
[Port Status]
A      B      C      D      E      F      H      J      K
FE1   FE1   FE1   FE1   FE1   o      o      o      o

[DISPLAY]                                [SETUP]
C -> Display System Configuration        S -> System Setup
Q -> Alarm Queue Summary                P -> Password Setup
I -> Information Summary                M -> System Alarm Setup
                                         L -> Download/Upload Firmware
                                         T -> Download/Upload Configuration
                                         R -> Store/Retrieve Configuration

[LOG]                                     [MISC]
U -> Choose a Unit                      A -> Alarm Cut Off
F -> Log Off [SETUP],[MISC] Menu        X -> Clear Alarm Queue
O -> Log On  [SETUP],[MISC] Menu        Y -> Controller Return to Default
                                         Z -> Controller Reset
                                         K -> Load All Ports Default

>>SPACE key to refresh or enter a command ==>
```

Then, move the cursor to the right to "System" and press **ENTER**.

```
LOOP V4200-9          === System Setup ===          09:25:55 09/06/2000

>> Select System_setup Type ?  MAP  PORT_BACKUP  *SYSTEM  CLOCK
```

To set the multicast feature, move the cursor down and to the right to select the "TSI_FUNC" setting.

```
LOOP V4200-9          === System Setup (SYSTEM) ===  09:51:02 04/12/2001

[System]
Time/Date       :14:28:37 07/05/2001
IP Interface    :ETHERNET_PORT
IP Address      :000.000.000.000 Subnet:000.000.000.000 Gateway:000.000.000.000
Trap IP Address:255.255.255.255
Community Name  :public
Device Name     :LOOP V4200-9
System Location:8F,No. 8,Hsin Ann Rd.
                Science-Based Industrial Park
                Hsinchu,30077 Taiwan

System Contact  :Name: FAE Tel:+886-3-5787696 Fax:+886-3-5787695
                E-mail:FAE@loop.com.tw

Baud Rate      : 9600          TSI_FUNC: 1:N(Multicast)
Data Length    : 8-Bits
Stop Bit       : 1-Bit
Parity         : NONE
XON_XOFF       : XOFF

<< ESC key to return to previous menu >>
```

Use **TAB** to change the value to 1:N(Multicast).

Press **ESC** and save the configuration.

Appendix A

Now, setup the backup feature.

Move the cursor to the left to "PORT_BACKUP" and press **ENTER**.

```

LOOP V4200-9                === System Setup ===                09:25:55 09/06/2000

>> Select System_setup Type ? *MAP  *PORT_BACKUP  SYSTEM  CLOCK
    
```

Move the cursor to the position under Port A.

Press **TAB** until PORT B is listed in the cell.

This will set Port B to backup Port A.

```

LOOP V4200-9                === System Setup ( BACKUP ) ===    10:47:58 09/06/2000
ARROW KEYS: CURSOR MOVE, TAB: ROLL OPTIONS
  PORT A PORT B PORT C PORT D PORT E PORT F PORT H PORT J PORT K PORT Z
  FE1    FE1    FE1    FE1    FE1                                INBAND
BACK NONCAS NONCAS NONCAS NONCAS NONCAS
UP      =====
BY      PORT B
<< Press ESC key to return to previous menu >>
    
```

Press **ESC** and save the configuration.

Now, setup the Time Slot Interchange mapping.

Move the cursor to "MAP" and press **ENTER**.

```

LOOP V4200-9                === System Setup ===                09:25:55 09/06/2000

>> Select System_setup Type ? *MAP  PORT_BACKUP  SYSTEM  CLOCK
    
```

First, map the Multicast feature.

Move the cursor to the blank space in column E.

Use **TAB** to select Port C.

Move the cursor to the right and change 00 to 01.

Do this for the entire column for Port E.

```

LOOP V4200-9                === System Setup ( MAP ) ===        09:25:55 09/06/2000
ARROW KEYS: CURSOR MOVE, Please Input: 0~9, BACKSPACE to edit
  PORT A PORT B PORT C PORT D PORT E PORT F PORT H PORT J PORT K PORT Z
TIME FE1  FE1  FE1  FE1  FE1
SLOT NONCAS NONCAS NONCAS NONCAS NONCAS
=====
 1 d   00 d   00 d   00 d   00 d C 01 d   00 d   00 d   00 d   00
 2 d   00 d   00 d   00 d   00 d C 01 d   00 d   00 d   00 d   00
 3 d   00 d   00 d   00 d   00 d C 01 d   00 d   00 d   00 d   00
 4 d   00 d   00 d   00 d   00 d C 01 d   00 d   00 d   00 d   00
 5 d   00 d   00 d   00 d   00 d C 01 d   00 d   00 d   00 d   00
 6 d   00 d   00 d   00 d   00 d C 01 d   00 d   00 d   00 d   00
 7 d   00 d   00 d   00 d   00 d C 00 d   00 d   00 d   00 d   00
 8 d   00 d   00 d   00 d   00 d C 01 d   00 d   00 d   00 d   00
 9 d   00 d   00 d   00 d   00 d C 01 d   00 d   00 d   00 d   00
10 d   00 d   00 d   00 d   00 d C 01 d   00 d   00 d   00 d   00
11 d   00 d   00 d   00 d   00 d C 01 d   00 d   00 d   00 d   00
12 d   00 d   00 d   00 d   00 d C 01 d   00 d   00 d   00 d   00
13 d   00 d   00 d   00 d   00 d C 01 d   00 d   00 d   00 d   00
14 d   00 d   00 d   00 d   00 d C 01 d   00 d   00 d   00 d   00
15 d   00 d   00 d   00 d   00 d C 01 d   00 d   00 d   00 d   00
16 d   00 d   00 d   00 d   00 d C 01 d   00 d   00 d   00 d   00
<< ESC key to previous menu, SPACE key to another page >>    PAGE1
    
```

Appendix A

Press the space bar to view the rest of the time slots (Time slots 17-31).

Do not change anything under Port C.

Now, setup the backup mapping.

Move the cursor to the blank space under Column A.

Use **TAB** to select Port D.

Move the cursor to the right and change 00 to 01.

Move the cursor to the blank space under Column D.

Use **TAB** to select Port A.

Move the cursor to the right and change 00 to 01.

There is no need to map Port B, because that is taken care of by the backup feature.

The final map should look like this:

```

LOOP V4200-9          === System Setup ( MAP ) ===          09:25:55 09/06/2000
ARROW KEYS: CURSOR MOVE, Please Input: 0~9, BACKSPACE to edit
  PORT A  PORT B  PORT C  PORT D  PORT E  PORT F  PORT H  PORT J  PORT K  PORT Z
TIME FE1   FE1   FE1   FE1   FE1
SLOT NONCAS NONCAS NONCAS NONCAS NONCAS
=====
 1 d D 01 d 00 d 00 d A 01 d C 01 d 00 d 00 d 00 d 00
 2 d 00 d 00 d 00 d 00 d C 01 d 00 d 00 d 00 d 00
 3 d 00 d 00 d 00 d 00 d C 01 d 00 d 00 d 00 d 00
 4 d 00 d 00 d 00 d 00 d C 01 d 00 d 00 d 00 d 00
 5 d 00 d 00 d 00 d 00 d C 01 d 00 d 00 d 00 d 00
 6 d 00 d 00 d 00 d 00 d C 01 d 00 d 00 d 00 d 00
 7 d 00 d 00 d 00 d 00 d C 00 d 00 d 00 d 00 d 00
 8 d 00 d 00 d 00 d 00 d C 01 d 00 d 00 d 00 d 00
 9 d 00 d 00 d 00 d 00 d C 01 d 00 d 00 d 00 d 00
10 d 00 d 00 d 00 d 00 d C 01 d 00 d 00 d 00 d 00
11 d 00 d 00 d 00 d 00 d C 01 d 00 d 00 d 00 d 00
12 d 00 d 00 d 00 d 00 d C 01 d 00 d 00 d 00 d 00
13 d 00 d 00 d 00 d 00 d C 01 d 00 d 00 d 00 d 00
14 d 00 d 00 d 00 d 00 d C 01 d 00 d 00 d 00 d 00
15 d 00 d 00 d 00 d 00 d C 01 d 00 d 00 d 00 d 00
16 d 00 d 00 d 00 d 00 d C 01 d 00 d 00 d 00 d 00

<< ESC key to previous menu, SPACE key to another page >>          PAGE1
  
```

Press **ESC** and save the configuration.

Finally, the new configurations should be stored so they will not be deleted upon a power reset.

Press **ESC** to return to the main menu.

Press "R" to activate the Store/Retrieve Configuration screen

```

LOOP V4200-9          === Controller Menu ===          10:48:35 09/06/2000
Serial Number: 10001  Connect_port: SUPV_PORT
Version           : HW H/W VER.E SW S3.Q4 05/24/2002
Start Time       : 15:35:17 06/25/2002          PWR1: active  PWR2: active
[Port Status]
A   B   C   D   E   F   H   J   K
o   o   o   FE1 FT1 DTE MDSL MDSL MDSL

[DISPLAY]                [SETUP]
C -> Display System Configuration  S -> System Setup
Q -> Alarm Queue Summary          P -> Password Setup
I -> Information Summary          M -> System Alarm Setup
                                  L -> Download/Upload Firmware
                                  T -> Download/Upload Configuration
                                  R -> Store/Retrieve Configuration

[LOG]                    [MISC]
U -> Choose a Unit          A -> Alarm Cut Off
F -> Log Off [SETUP],[MISC] Menu  X -> Clear Alarm Queue
O -> Log On  [SETUP],[MISC] Menu   Y -> Controller Return to Default
                                  Z -> Controller Reset
                                  K -> Load All Ports Default

>>SPACE key to refresh or enter a command ===>
  
```

Appendix A

Move the cursor to "Store" and press **ENTER**.

```
LOOP V4200-9          === Store / Retrieve Configuration ===          11:20:53 09/06/2000

>> Select ?  *STORE  RETRIEVE
```

Press "Y" to store the configuration.

Enter the password for the system. The default password is "loop."

When configuration is stored, press **ESC**, then **ESC** to return to the main menu.

This configuration has been tested as sound. If you have any questions, please feel free to contact your Loop representative.

Note for Appendix A

Note: Backup functions can be done for multiple pairs but they must be set up one pair at a time. If backing up more than one pair do not use the multicast and broadcast functions.

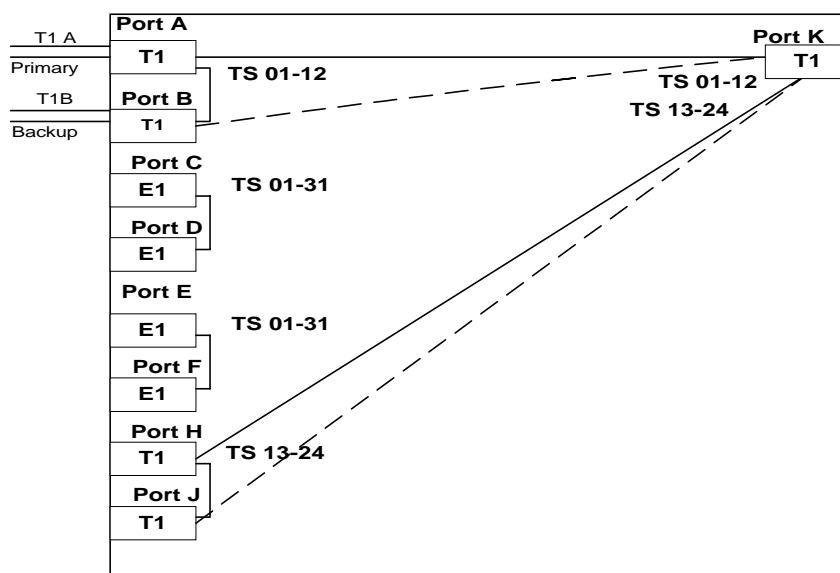

This example shows a Loop 4200-9 equipped with both E1 and T1 cards. Port A is backed up by Port B, Port C is backed up by Port D, Port E is backed up by Port F, and Port H is backed up by Port J. Ports A and H are mapped to Port K.

7. Appendix B: Channel Bank with digital Monitoring Function

Channel Bank with digital Monitoring Function

Introduction

Among its many applications of the Loop-V 4200-9, an IAD (integrated access device), is a channel bank. In this application, it will also have a digital monitoring capability, which is not available in a conventional channel bank. Digital monitoring differs from analog monitoring in that (a) no tap on the voice circuit is needed, avoiding any detection, and (b) the two directions of the conversation remain separated, providing superior performance. This application note will describe the set-up for the channel bank application including the monitoring function.

Of the 9 ports on the Loop-V 4200-9, the E1 plug-in card should go into Port A. This is because Port A is wired to the bantam jack on the front panel, providing easy access to the E1 line for installation and maintenance. The PORT A monitoring jack will monitor the E1 line, whereas this application provides for the monitoring of any single voice channel within the E1. The other 8 ports each will have a QFXS (or QFXO depending on the need) plugged in, resulting in 32 voice channels available, four from each Quad FXS plug-in card. Since E1 uses 30 time slots for voice, the two extra voice channels (usually voice channels 3 and 4 of Port K) can be assigned for monitoring, one for each direction of conversation.

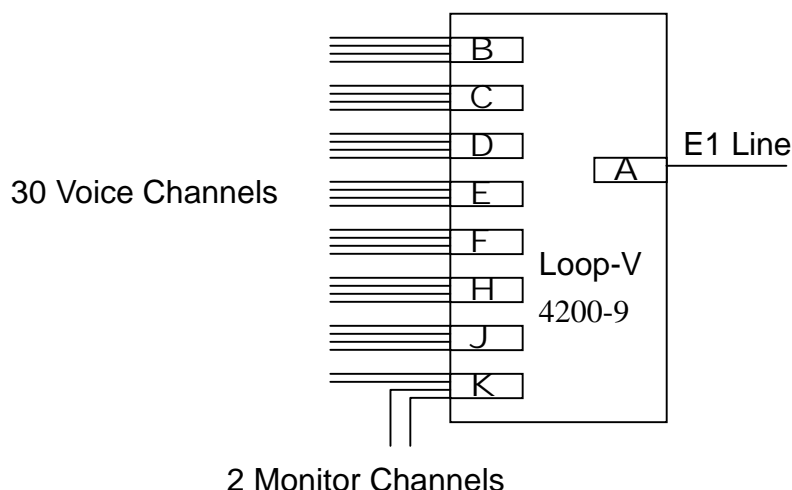

Loop-V 4200-9 Used as Channel Bank with Monitoring

The monitoring capability is derived from the “multicast” function of the Loop-V 4200-9. Multicast is an operation where one time slot is mapped to many time slots.

Hardware

Install Loop-V 4200-9 according to instructions.

Install an E1 plug-in card into Port A of the Loop-V 4200-9.

Install 8 QFXS (or QFXO) plug-in card into Ports B, C, D, E, F, H, J, and K

Install a VT-100 terminal into the “console” port on the front of the Loop-V 4200-9.

Appendix B

Enable Monitor with Multicast

If monitoring is not needed, the “multicast” function should be OFF to simplify the configuration. To allow monitoring, the multicast function is setup, in two places, the SYSTEM SETUP and the Time Slot Interchange MAP. First, in SYSTEM, the Multicast function must be enabled.

From the main menu, press “S” for System setup.

```
LOOP V4200-9      === Controller Menu ===      10:48:35 09/06/2000
Serial Number: 10001   Connect_port: SUPV_PORT
Version           : HW H/W VER.E SW S3.Q4 05/24/2002
Start Time       : 15:35:17 06/25/2002        PWR1: active   PWR2: active
[Port Status]
A      B      C      D      E      F      H      J      K
FE1   QFXS   QFXS   QFXS   QFXS   QFXS   QFXS   QFXS   QFXS

[DISPLAY]                                [SETUP]
C -> Display System Configuration        S -> System Setup
Q -> Alarm Queue Summary                P -> Password Setup
I -> Information Summary                M -> System Alarm Setup
                                         L -> Download/Upload Firmware
                                         T -> Download/Upload Configuration
                                         R -> Store/Retrieve Configuration

[LOG]                                     [MISC]
U -> Choose a Unit                      A -> Alarm Cut Off
F -> Log Off [SETUP],[MISC] Menu        X -> Clear Alarm Queue
O -> Log On  [SETUP],[MISC] Menu        Y -> Controller Return to Default
                                         Z -> Controller Reset
                                         K -> Load All Ports Default

>>SPACE key to refresh or enter a command ===>
```

Then, move the cursor to the right to “system” and press ENTER.

```
LOOP V4200-9      === System Setup ===      09:25:55 09/06/2000
>> Select System_setup Type ?  MAP  PORT_BACKUP  *SYSTEM  CLOCK
```

To set the multicast feature, move the cursor down and to the right to select the “TSI_FUNC” setting. Use TAB to change the value to 1:N(Multicast). Press ESC and save the configuration.

```
LOOP V4200-9      === System Configuration ===      09:51:02 04/12/2001

[System]
Time/Date       :14:28:37 07/05/2001
IP Interface    :ETHERNET_PORT
IP Address      :000.000.000.000 Subnet:000.000.000.000 Gateway:000.000.000.000
Trap IP Address:255.255.255.255
Community Name  :public
Device Name     :LOOP V4200-9
System Location:8F,No. 8,Hsin Ann Rd.
                Science-Based Industrial Park
                Hsinchu,30077 Taiwan

System Contact  :Name: FAE Tel:+886-3-5787696 Fax:+886-3-5787695
                E-mail:FAE@loop.com.tw

Baud Rate      : 9600                TSI_FUNC: 1:N(Multicast)
Data Length    : 8-Bits
Stop Bit       : 1-Bit
Parity         : NONE
XON_XOFF      : XOFF

<< ESC key to return to previous menu >>
```

Appendix B

Channel Bank Configuration

Next, setup the Time Slot Interchange mapping for a channel bank. We will assume CAS signaling, for which time slot 16 is reserved for signaling. If non-CAS is used, time slot 16 may still be used for CCS signaling. In either case, time slot 16 is reserved.

Move the cursor to "MAP" and press ENTER.

```
LOOP V4200-9          === System Setup ===          09:25:55 09/06/2000
>> Select System_setup Type ? *MAP  PORT_BACKUP  SYSTEM  CLOCK
```

First, establish map for channel bank. In this case, the 4 voice channels of Port B is mapped to time slots 1 to 4 of Port A, the 4 voice channels of Port C is mapped to time slots 5 to 8, and so forth.

Note: When "multicast" is selected, reciprocal time slot assignments are not automatic. This means that when time-slot 1 of PORT A is assigned to time-slot 1 of PORT B, the user must manually also assign time-slot 1 of PORT B to time-slot 1 of PORT A.

Use TAB to select Port A.

Move the cursor to the first time slot of PORT A and change to v B 01 (v for voice, B for PORT B, and 01 for time slot 1), the second time slot to v B 02, and so forth to v B 04. Then time slot 5 is changed to v C 01, followed by v C 02 and so forth for all the PORTs B to K. Note time slot 16 is skipped.

Now the reciprocal time slots are assigned. For PORT B, the four time slots are assigned v A 01 to v A 04. For PORT C, assign v A 05 to v A 08, and so on. Time slot 16 of A is skipped.

Note that time slot 16 of PORT A is reserved and the last two channels of PORT K are still unassigned. The MAP now looks like this.

```
LOOP V4200-9          === System Setup ( MAP ) ===          09:25:55 09/06/2000
ARROW KEYS: CURSOR MOVE, Please Input: 0~9, BACKSPACE to edit
  PORT A  PORT B  PORT C  PORT D  PORT E  PORT F  PORT H  PORT J  PORT K  PORT Z
TIME  FE1    QFXS    QFXS    QFXS    QFXS    QFXS    QFXS    QFXS    QFXS    Inband
SLOT  CAS    A-LAW    A-LAW    A-LAW    A-LAW    A-LAW    A-LAW    A-LAW    A-LAW
=====
  1  v B  01  v A  01  v A  05  v A  09  v A  13  v A  18  v A  22  v A  26  v A  30
  2  v B  02  v A  02  v A  06  v A  10  v A  14  v A  19  v A  23  v A  27  v A  31
  3  v B  03  v A  03  v A  07  v A  11  v A  15  v A  20  v A  24  v A  28  v   00
  4  v B  04  v A  04  v A  08  v A  12  v A  17  v A  21  v A  25  v A  29  v   00
  5  v C  01
  6  v C  02
  7  v C  03
  8  v C  04
  9  v D  01
 10  v D  02
 11  v D  03
 12  v D  04
 13  v E  01
 14  v E  02
 15  v E  03
 16  s    00
<< ESC key to previous menu, SPACE key to another page >>          PAGE1
```

Appendix B

Press the space bar to view the next page showing the rest of the time slots of PORT A (time slots 17-31).

```

LOOP V4200-9      === System Setup ( MAP ) ===          09:25:55 09/06/2000
ARROW KEYS: CURSOR MOVE, Please Input: 0~9, BACKSPACE to edit
   PORT A  PORT B  PORT C  PORT D  PORT E  PORT F  PORT H  PORT J  PORT K  PORT Z
TIME  FE1    QFXS   QFXS    QFXS   QFXS   QFXS   QFXS   QFXS   QFXS   Inband
SLOT  CAS    A-LAW   A-LAW   A-LAW   A-LAW   A-LAW   A-LAW   A-LAW   A-LAW
=====
17  v  E  04
18  v  F  01
19  v  F  02
20  v  F  03
21  v  F  04
22  v  H  01
23  v  H  02
24  v  H  03
25  v  H  04
26  v  J  01
27  v  J  02
28  v  J  03
29  v  J  04
30  v  K  01
31  v  K  02

<< ESC key to previous menu, SPACE key to another page >>          PAGE2

```

The normal configuration for a channel bank is now complete.

Press ESC and save the configuration.

Note: If common channel signaling is used, time slot 16 can be used to carry the signaling channel. However, to insert the signaling channel, a data card, such as a V.35 card, must be plugged into one of the ports. PORT A must be configured to NON-CAS and time slot 16 of PORT A must be labeled d for data. The port taken by the data card will decrease the number of available voice channels carried to 28.

Finally, the new configurations should be STORED so they will not be deleted upon a power reset.

Press ESC to return to the main menu.

Press "R" to activate the Store/Retrieve Configuration screen

```

LOOP V4200-9      === Controller Menu ===              10:48:35 09 / 06 / 2000
Serial Number: 10001  Connect_port: SUPV_PORT
Version          : HW H/W VER.E SW S3.Q4 05/24/2002
Start Time      : 15:35:17 06/25/2002          PWR1: active   PWR2: active
[Port Status]
A    B    C    D    E    F    H    J    K
FE1  QFXS QFXS QFXS QFXS QFXS QFXS QFXS QFXS

[DISPLAY]                [SETUP]
C -> Display System Configuration  S -> System Setup
Q -> Alarm Queue Summary          P -> Password Setup
I -> Information Summary          M -> System Alarm Setup
                                   L -> Download/Upload Firmware
                                   T -> Download/Upload Configuration
                                   R -> Store/Retrieve Configuration

[LOG]                    [MISC]
U -> Choose a Unit              A -> Alarm Cut Off
F -> Log Off [SETUP],[MISC] Menu X -> Clear Alarm Queue
O -> Log On  [SETUP],[MISC] Menu Y -> Controller Return to Default
                                   Z -> Controller Reset
                                   K -> Load All Ports Default

>>SPACE key to refresh or enter a command ===>

```

Appendix B

Move the cursor to “store” and press ENTER.

```
LOOP V4200-9          === Store / Retrieve ===          11:20:53 09/06/2000

>> Select ?  *STORE  RETRIEVE
```

Press “Y” to store the configuration.

If required, enter the password for the system. The default password is “loop.”

When configuration is stored, press ESC, then ESC again to return to the main menu.

Note: To save set-up time by customer, the map for a normal channel bank can be set up by as factory default prior to shipping, or downloaded from a PC. See sales representative for this service.

Monitor a Voice Channel

So far, the monitor function has not been mapped. To complete the monitor function, determine which voice channel is to be monitored. Then, the voice signal from the local port is assigned to the third channel of PORT K, and the voice signal from the far end of the same voice connection is assigned to the fourth channel of PORT K.

For example, to set up monitoring of the second channel of PORT C, assign the third channel of PORT K to v C 02, and assign the fourth channel of PORT K to v A 06. The first page of the map will now look like this.

```
LOOP V4200-9          === System Setup ( MAP ) ===          09:25:55 09/06/2000
ARROW KEYS: CURSOR MOVE, Please Input: 0~9, BACKSPACE to edit
TIME  PORT A  PORT B  PORT C  PORT D  PORT E  PORT F  PORT H  PORT J  PORT K  PORT Z
SLOT  FE1    QFXS   QFXS   QFXS   QFXS   QFXS   QFXS   QFXS   QFXS   Inband
      CAS    A-LAW  A-LAW  A-LAW  A-LAW  A-LAW  A-LAW  A-LAW  A-LAW
=====
 1  v B  01  v A  01  v A  05  v A  09  v A  13  v A  18  v A  22  v A  26  v A  30
 2  v B  02  v A  02  v A  06  v A  10  v A  14  v A  19  v A  23  v A  27  v A  31
 3  v B  03  v A  03  v A  07  v A  11  v A  15  v A  20  v A  24  v A  28  v C  02
 4  v B  04  v A  04  v A  08  v A  12  v A  17  v A  21  v A  25  v A  29  v A  06
 5  v C  01
 6  v C  02
 7  v C  03
 8  v C  04
 9  v D  01
10  v D  02
11  v D  03
12  v D  04
13  v E  01
14  v E  02
15  v E  03
16  s    00

<< ESC key to previous menu, SPACE key to another page >>          PAGE1
```

Note that v C 02 now appears both in time slot 6 of PORT A and in time slot 3 of PORT K, and that v A 06 appears both in time slot 2 of PORT C and in time slot 3 of PORT K. This is allowed when the “multicast” feature is enabled.

Press ESC and save the configuration. The monitor function is now activated. If this configuration is not STORED, the monitor function will disappear on next power up. If not STORED, the monitor function can be removed by the RETRIEVE command, command R of the main menu.

To monitor a different channel, if the monitor configuration is not STORED, do the RETRIEVE command, then repeat the above procedure. If the monitor configuration is STORED, then manually restore to the normal channel bank configuration, followed by the above procedure.

Appendix B

To listen to, or to record, the voice signals on the channel monitored, two telephone sets, or two recording devices, are needed, one attached to Channel 3 or PORT K for the local signal, and another attached to Channel 4 of PORT K for the distant signal. Of course, in the case where only one telephone or one recording device is used, signals of the two directions must be combined. See sales representative for a combiner.

This channel bank application, including monitoring, has been tested. If you have any questions, please feel free to contact your sales representative.

8. Appendix C: 1 : 1 Line Protection

Introduction

Among the many applications of the Loop-V 4200-9, an IAD (integrated access device) is 1:1 or 1:N line protection. 1:1 line protection exists when the system is set up so that a backup line (or lines in the case of 1:N) will be switched into service if the working line fails. In such a case, it must be switched in at each end of the line. The 1:1 line protection function exists only for E1 and T1 cards.

In the diagram below, working ports and protection ports are directly connected to the Time Slot Interchange (TSI). Signal paths are clearly marked in bold lines.

The protection function is set up but is not in use because the lines at the working ports are functioning properly. For example, the line at working Port A is connected to the line at working Port J.

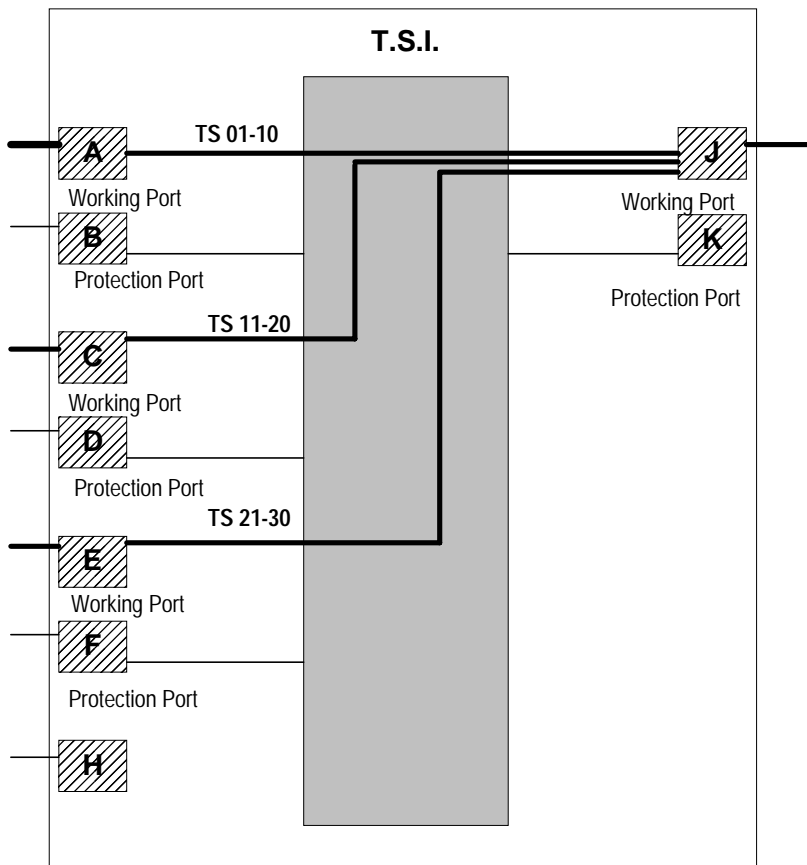

In the example below, a line failure has occurred at Port A. The protection function has kicked in and the system has switched to protection port B as shown below.

Appendix B

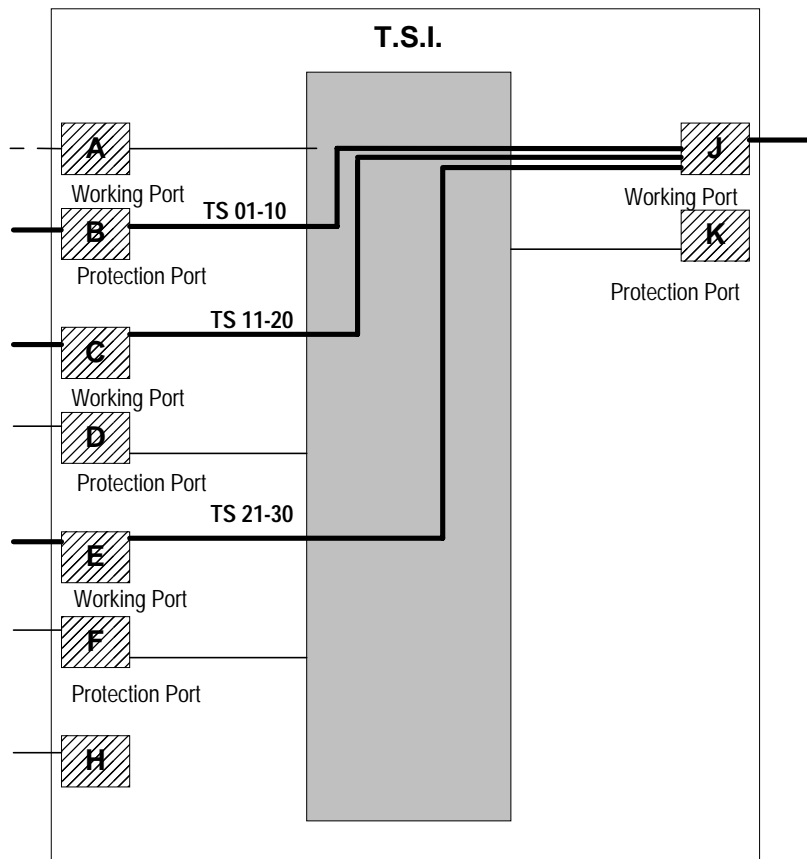

Hardware

Install the Loop-V 4200-9 according to instructions in the user manual.

Install plug-in cards into Ports A, B, C, D, E, F, J, and K. E1 cards, T1 cards, or a combination of E1 and T1 cards may be used, but for each port pair, the working port and the protecting port must have the same type of plug-in cards installed.

Do not install any cards into Port H.

Install a VT-100 terminal via the console port on the front of the Loop-V 4200-9.

Appendix B

Setting up the TSI Map

Press 'S' from the Controller Menu to access the System Setup screen.

```
LOOP-V 4200-9          === Controller Menu ===          17:30:47 01/18/2002
Serial Number: 10070   Connect_port: SUPV_PORT
Version      : HW H/W VER.E SW S3.Q4 05/24/2002
Start Time   : 15:35:17 06/25/2002          PWR1: active   PWR2: active
[Port Status]
A   B   C   D   E   F   H   J   K
FE1 FE1 FE1 FE1 FE1 FE1  o   FE1 FE1

[DISPLAY]                                [SETUP]
C -> Display System Configuration        S -> System Setup
Q -> Alarm Queue Summary                P -> Password Setup
I -> Information Summary                M -> System Alarm Setup
                                        L -> Firmware Download/Upload
                                        T -> Configuration Download/Upload
                                        V -> Store/Retrieve Configuration

[LOG]                                     [MISC]
U -> Choose a Unit                      A -> Alarm Cut Off
F -> Log Off [SETUP],[MISC] Menu        X -> Clear Alarm Queue
O -> Log On  [SETUP],[MISC] Menu        Y -> Controller Return to Default
                                        Z -> Controller Reset
                                        K -> Load All Ports Default

>>SPACE key to refresh or enter a command ===>
```

Select "PORT_BACKUP" by moving the asterisk with the 'arrow' keys. Then press 'ENTER'.

```
LOOP V4200-9          === System Setup ===          09:25:55 07/19/2000

>> Select System_setup Type ?  MAP  *PORT_BACKUP  SYSTEM  CLOCK
```

The System Setup (BACKUP) screen will appear. Use the 'arrow' keys and the 'TAB' keys to set up the backup ports as shown below. Then press 'ESC' to return to the System Setup screen.

```
LOOP-V 4200-9          === System Setup ( BACKUP ) ===          10:29:09 01/18/2002
ARROW KEYS: CURSOR MOVE, TAB: ROLL OPTIONS
  PORT A PORT B PORT C PORT D PORT E PORT F PORT H PORT J PORT K PORT Z
  FE1   FE1   FE1   FE1   FE1   FE1           FE1   FE1   INBAND
BACK NONCAS NONCAS NONCAS NONCAS NONCAS NONCAS          NONCAS NONCAS
UP  =====
BY  PORT B          PORT D          PORT F          PORT K

<< Press ESC key to return to previous menu >>
```

Select "MAP" by moving the asterisk with the 'arrow' keys. Then press 'ENTER'.

```
LOOP V4200-9          === System Setup ===          09:25:55 07/19/2000

>> Select System_setup Type ?  *MAP  PORT_BACKUP  SYSTEM  CLOCK
```

Appendix B

The System Setup (MAP) screen will appear. Use the 'TAB' key to select PORT A. Move the cursor to the first time slot in PORT A and change to 'd J 01' (d for data, J for Port J and 01 for time slot 1). Similarly, map time slots 2-10 of PORT A to time slots 2-10 of PORT J. In the Port C column, map time slots 11—20 of Port C to time slots 11—20 of Port J. In the Port E column, map time slots 21-30 of Port E to time slots 21-30 of Port J. The map will appear as shown in the screens below.

```

LOOP-V 4200-9          === System Setup ( MAP ) ===          10:31:50 01/18/2002
ARROW KEYS: CURSOR MOVE, TAB: ROLL OPTIONS
  PORT A PORT B PORT C PORT D PORT E PORT F PORT H PORT J PORT K PORT Z
TIME FE1  FE1  FE1  FE1  FE1  FE1  FE1  FE1  FE1  INBAND
SLOT NONCAS NONCAS NONCAS NONCAS NONCAS NONCAS NONCAS NONCAS NONCAS
=====
  1 d J 01 d  00 d  00 d  00 d  00 d  00  d A 01 d  00 d  00
  2 d J 02 d  00 d  00 d  00 d  00 d  00  d A 02 d  00 d  00
  3 d J 03 d  00 d  00 d  00 d  00 d  00  d A 03 d  00 d  00
  4 d J 04 d  00 d  00 d  00 d  00 d  00  d A 04 d  00 d  00
  5 d J 05 d  00 d  00 d  00 d  00 d  00  d A 05 d  00 d  00
  6 d J 06 d  00 d  00 d  00 d  00 d  00  d A 06 d  00 d  00
  7 d J 07 d  00 d  00 d  00 d  00 d  00  d A 07 d  00 d  00
  8 d J 08 d  00 d  00 d  00 d  00 d  00  d A 08 d  00 d  00
  9 d J 09 d  00 d  00 d  00 d  00 d  00  d A 09 d  00 d  00
 10 d J 10 d  00 d  00 d  00 d  00 d  00  d A 10 d  00 d  00
 11 d  00 d  00 d J 11 d  00 d  00 d  00  d C 11 d  00 d  00
 12 d  00 d  00 d J 12 d  00 d  00 d  00  d C 12 d  00 d  00
 13 d  00 d  00 d J 13 d  00 d  00 d  00  d C 13 d  00 d  00
 14 d  00 d  00 d J 14 d  00 d  00 d  00  d C 14 d  00 d  00
 15 d  00 d  00 d J 15 d  00 d  00 d  00  d C 15 d  00 d  00
 16 d  00 d  00 d J 16 d  00 d  00 d  00  d C 16 d  00 d  00
<< ESC key to previous menu, SPACE key to another page >>  J 01 >d A 01  PAGE1
  
```

```

LOOP-V 4200-9          === System Setup ( MAP ) ===          10:32:06 01/18/2002
ARROW KEYS: CURSOR MOVE, TAB: ROLL OPTIONS
  PORT A PORT B PORT C PORT D PORT E PORT F PORT H PORT J PORT K PORT Z
TIME FE1  FE1  FE1  FE1  FE1  FE1  FE1  FE1  FE1  INBAND
SLOT NONCAS NONCAS NONCAS NONCAS NONCAS NONCAS NONCAS NONCAS NONCAS
=====
 17 d  00 d  00 d J 17 d  00 d  00 d  00  d C 17 d  00 d  00
 18 d  00 d  00 d J 18 d  00 d  00 d  00  d C 18 d  00 d  00
 19 d  00 d  00 d J 19 d  00 d  00 d  00  d C 19 d  00 d  00
 20 d  00 d  00 d J 20 d  00 d  00 d  00  d C 20 d  00 d  00
 21 d  00 d  00 d  19 d  00 d J 21 d  00  d E 21 d  00 d  00
 22 d  00 d  00 d  00 d  00 d J 22 d  00  d E 22 d  00 d  00
 23 d  00 d  00 d  00 d  00 d J 23 d  00  d E 23 d  00 d  00
 24 d  00 d  00 d  00 d  00 d J 24 d  00  d E 24 d  00 d  00
 25 d  00 d  00 d  00 d  00 d J 25 d  00  d E 25 d  00 d  00
 26 d  00 d  00 d  00 d  00 d J 26 d  00  d E 26 d  00 d  00
 27 d  00 d  00 d  00 d  00 d J 27 d  00  d E 27 d  00 d  00
 28 d  00 d  00 d  00 d  00 d J 28 d  00  d E 28 d  00 d  00
 29 d  00 d  00 d  00 d  00 d J 29 d  00  d E 29 d  00 d  00
 30 d  00 d  00 d  00 d  00 d J 30 d  00  d E 30 d  00 d  00
 31 d  00 d  00 d  00 d  00 d  00 d  00  d  00 d  00 d  00
<< ESC key to previous menu, SPACE key to another page >>          PAGE2
  
```

Appendix B

Clock Setup

If your application is receiving its master clock source from the working line, you must set the second clock source to the backup line. This is necessary to prevent the loss of a clock source in the event of line failure.

Press 'S' from the Controller Menu to access the System Setup screen. Select "Clock" by moving the asterisk with the 'arrow' keys. Then press 'ENTER'.

```
LOOP-V 4200-9          === System Setup ===          03:51:28 03/12/2002

>> Select System_setup Type ?  MAP  PORT_BACKUP  SYSTEM  *CLOCK
```

The System Setup (CLOCK) screen will appear. Use the 'arrow' keys and the 'TAB' keys to set up the clock sources. In the example below, the Master Clk. Source is set to PORT_A because the working line is A. The Second Clk. Source is set to PORT_B, because the protection line is B. Press 'ESC' to return to the System Setup screen. A prompt (Change configuration (Y/N)?) will appear. Press "Y". Press 'ESC' again to return to the Controller Menu.

```
LOOP-V 4200-9          === System Setup (CLOCK) ===    03:51:02 03/12/2002
ARROW KEYS: CURSOR MOVE, TAB: ROLL OPTIONS

Master_Clk Source : PORT_A
Second_Clk Source : PORT_B
Current Clock     : MASTER_CLK
Clk_Recover_Mode : AUTOMATIC
Clock Status      : NORMAL

<< Change configuration (Y/N)? >>
```

**AFFIDAVIT FOR CONNECTION OF CUSTOMER PREMISES EQUIPMENT
TO 1.544 MBPS AND/OR SUBRATE DIGITAL SERVICES**

For the work to be performed in the certified territory of

Telco's Name: _____

State of: _____

Country of: _____

I, _____, of _____
(Name Authorized Representative) (Customer Name)

_____, _____
(Customer's Address) (Telephone Number)

being duly sworn, state:

I have responsibility for the operation and maintenance of the terminal equipment to be connected to 1.544 Mbps and/or _____ subrate digital service. The terminal equipment to be connected complies with Part 68 of the FCC rules except for the encoded analog content and billing protection specifications. With respect to encoded analog content and billing protection:

I attest that all operations associated with the establishment, maintenance and adjustment of the digital CPE, with respect to the analog content and encoded billing information, continually complies with Part 68 of the FCC Rules and Regulations.

The digital CPE does not transmit digital signals containing encoded analog content or billing information which is intended to be decoded within the telecommunications network.

The encoded analog content and billing protection is factory set and is not under the control of the customer.

I attest that operator(s)/maintainer(s) of the digital CPE responsible for the establishment, maintenance and adjustment of the encoded analog content and billing information has (have) been trained to perform these functions by successfully having completed one of the following: (Check appropriate blocks)

(a) A training course provided by the manufacturer/grantee of the equipment used to encode analog signals; or

(b) A training course provided by the customer or authorized representative, using training materials and instructions provided by the manufacturer/grantee of the equipment used to encode analog signals; or

(c) An independent training course (e.g., trade school or technical institution) recognized by the manufacturer/grantee of the equipment used to encode analog information; or

(d) In lieu of the preceding training requirements, the operator(s)/maintainer(s) is (are) under the control of a supervisor trained in accordance with _____ (circle one) above.

I agree to provide _____ (telco name) with the proper documentation to

(Telco's Name)

demonstrate compliance with the information as provided in the preceding paragraphs, if so requested.

_____ (Signature)

_____ (Title)

_____ (Date)

Subscribed and sworn to before me this _____ day of _____, _____

Notary Public

My commission expires: _____